

1" Vibration Resistant Lenses

Model	VS-MC35H1
Focal Length (f)	35 mm (35.10)
Maximum Aperture Ratio	1: 1.4
Angle of View (1")	18.3° × 18.3° (Diagonal: 25.8°)
M.O.D	300 mm
TV Distortion (1")	-0.31 %
Operation	Manual
Wavelength	Visible
Mount	C-Mount
Flange Back	17.526 mm
Sensor Size (max.)	1"
Filter Thread	M 30.5 P= 0.5
Weight (approx.)	72 g
Dimension	ϕ 36.5 (max.) × L = 35 mm

※ Note: Available with MC Focus Locking System, FNO (Iris Open) 5 .6 & 8

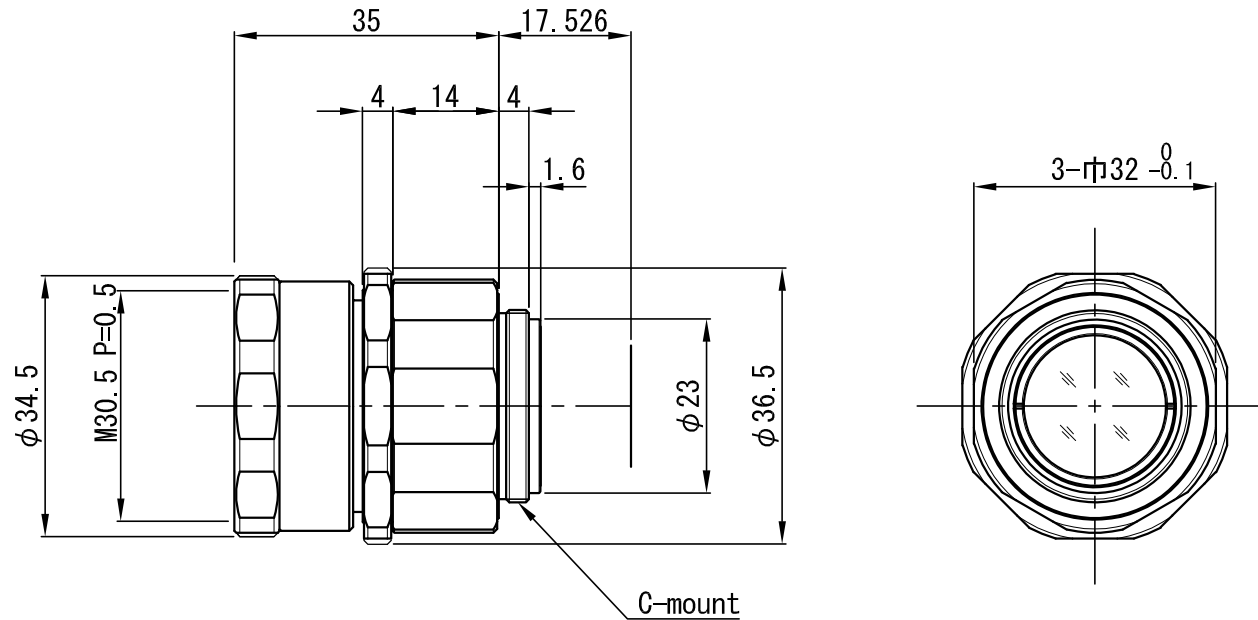

△×				APPROVED	CHECKED	MATERIAL 材料	-	CHAMFER 一般面取	-	QUANTITY 個数	
△×				T. A.	T. A.	TREATMENT 処理	-	FINISHING 仕上	-	X	
△×						TREATMENT CONTACT 処理接点	-	DECENTRATION 偏芯	-		
△×				DESIGNED	DRAWN	OVER 250 UP TO 1000	±0.3 ±0.5 ±1.0 ±0.2	ANGLE 角度	METHOD 図法	REMARK 適用 (機種名)	
△×				T. A.	H. M.	OVER 63 UP TO 250	±0.2 ±0.3 ±0.6 ±0.15	UNIT (mm)	-		VS-MC35H1
△× 1	型式表記訂正	18.08.22	H. M.			OVER 16 UP TO 63	±0.1 ±0.2 ±0.4 ±0.1				
NO.×箇所	REVISION 訂正事項	DATE	NAME			OVER 0 UP TO 16	±0.05 ±0.1 ±0.2 ±0.1	DATE	18.07.31	DRAW NO.	01DMC0403A2
						TOLERANCES	A B C S				