

# Basler sprint

## LINE SCAN CAMERAS



- Next generation CMOS dual line scan technology
- Up to 140 kHz at 2k or 4k resolution, up to 70 kHz at 8k resolution
- Color line scan with 70 kHz at 4k resolution
- High sensitivity at high speed with very low noise
- Flexible color concepts and high color fidelity

# OVERVIEW

## Fast, Faster, sprint

The Basler sprint family of line scan cameras includes members with 2k, 4k, and 8k resolution and different line rates. All sprint variants are based on a next generation dual line CMOS sensor designed exclusively for Basler.

The Basler sprint is aimed at applications where high sensitivity, excellent image quality, and the highest speed are required. This speed and image quality let sprint camera users increase efficiency and throughput in many vision applications.

## sprint CMOS Sensor Technology

To reach Basler's high goals for the sprint sensor, the positive properties of current sensor technologies were combined. The well-known image quality of CCD sensors was combined with the high speed of CMOS to achieve a "best of both worlds" result. The sprint development project resulted in a unique sensor design with a high QE (quantum efficiency) of up to 60%, a fill factor of 100%, and a very high SNR (signal-to-noise ratio) at low light conditions. This means that users will see very low noise levels and unique speed levels. A maximum line rate of 140 kHz can be reached at either 2k or 4k resolution. With 8k resolution a line rate of up to 70 kHz can be reached. The fact that there is no gap between the two active lines in the sensor makes it easy to fit the camera into both existing and new applications with no spatial artifacts.

### Your benefits include:

- Increased throughput with maximum line rates of up to 140 kHz
- Higher sensitivity
- More capable vision-based inspection
- AOI (area of interest) with linear speed increase
- Easy integration into your application
- 100% quality checked and calibrated to give you consistent performance and reliability



# OVERVIEW

The dual line sensor offers high flexibility so that the sprint can meet a wide variety of application requirements and can be easily integrated. Some of the main unique properties and features of the Basler sprint are:

■ **AOI (area of interest) with linear speed increase**

The AOI feature lets you focus precisely on the area of an object that is important to you. This means that the amount of data transmitted by the camera will be reduced and that the image processing application in your host PC will not be overloaded with unnecessary data. In addition, you may see a linear increase in the camera's speed by reducing the AOI.

■ **Time delayed line sum**

This feature uses the dual line sensor to scan each object line twice in a time delayed fashion. The double information is combined in the sprint's internal memory and this technique doubles the sprint's sensitivity. It also significantly reduces noise and results in a 3 dB increase in the SNR.

■ **Time delayed line averaging**

With this feature, time delayed line summing is performed and then the doubled information is averaged. The advantages are an increase of 3 dB in the SNR and an increase of 3 dB in the dynamic range.

■ **Binning**

Both horizontal and vertical binning are available. Either two pixels or four pixels can be binned together (see the graphics illustrating binning).

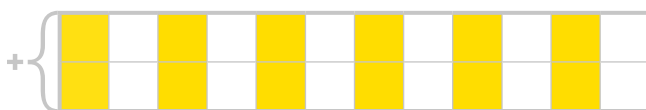

Vertical Binning

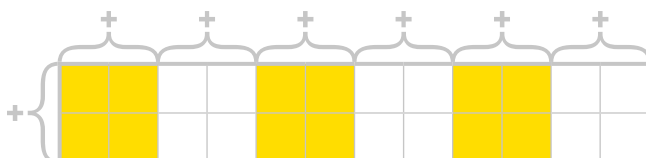

Horizontal and Vertical Binning

■ **Shading correction (flat field correction)**

DSNU (dark signal non-uniformity) and PRNU (photo response non-uniformity) can be performed to correct for the non-homogeneous behavior of lighting, optics, and the sensor that can be present in real world applications. Shading or vignetting caused by lenses can be compensated by the enhanced shading correction (ESC). The wide range of the ESC is very helpful for image processing, especially with larger sensors and lenses with shorter focal lengths (please ask for 'ESC models').

■ **Color**

A Bayer pattern filter is used to create the color version of the sprint. One line in the sensor reports red and green information and the second line reports green and blue information. Image data in a raw format is transferred to the frame grabber where color processing happens in a fast, reliable way similar to common color area scan cameras. Several color creation schemes can be implemented. Depending on the application needs, the active color concept can focus on speed and reducing the amount of data, or it can focus on higher color fidelity. For higher color fidelity, each object line is scanned twice, thus two times color information is available for each image point. This approach has a big advantage because standard lenses and frame grabbers can be used. Because there is no gap between the sensor's two active lines, adapting the camera to your application/object is easy and no spatial correction is needed (see the Bayer pattern graphic).



Bayer pattern filter - sensor has no gap between pixels or lines

# TECHNICAL DETAILS



## Specifications

Basler sprint	spL2048-39kc	spL2048-50km	spL2048-50kc	spL2048-70km	spL2048-70kc	spL2048-140km
<b>Camera</b>						
Sensor Size (pixels per line)	2048					
Sensor Type	Dual Line CMOS					
Mono / Color	Color	Mono	Color	Mono	Color	Mono
Pixel Size	10 µm x 10 µm					
Camera Link Pixel Clock*	40/80 MHz					
Max. Data Speed	160 MHz	160 MHz	320 MHz	160 MHz	320 MHz	320 MHz
Max. Line Rate	38.6 kHz	50 kHz	50 kHz	70 kHz	70 kHz	140 kHz
Pixel Depths	Selectable 8 bit, 10 bit, or 12 bit					
Video Output Format (taps)*	2/3	2	2/3/4/6/8	2	2/3/4/6/8	2/4/8
Synchronization	Via external signal or free run					
Exposure Control	Edge-controlled, level controlled, or programmable					
<b>Mechanical / Electrical</b>						
Housing Size (L x W x H)	48 mm x 87 mm x 62 mm					
Housing Temperature	Up to 50 °C					
Lens Mount	C-Mount, F-mount, M42					
Power Requirements	12 VDC (±10%), max. 6.0 W @ 12 VDC					
Weight (typical)	360 g (without F-Mount adapter)					
Conformity	CE, FCC, RoHS					

## Dimensions (in mm)

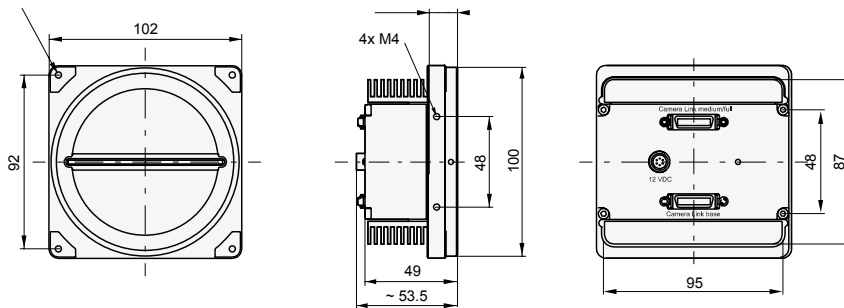

# TECHNICAL DETAILS



## Specifications

Basler sprint	spL4096-39km	spL4096-39kc	spL4096-50km	spL4096-50kc	spL4096-70km	spL4096-70kc	spL4096-140km	spL4096-140kc
<b>Camera</b>								
Sensor Size (pixels per line)	4096							
Sensor Type	Dual Line CMOS							
Mono / Color	Mono	Color	Mono	Color	Mono	Color	Mono	Color
Pixel Size	10 µm x 10 µm							
Camera Link Pixel Clock*	40/80 MHz							
Max. Data Speed	160 MHz	320 MHz	320 MHz	640 MHz	320 MHz	640 MHz	640 MHz	640 MHz
Max. Line Rate	38.6 kHz	38.6 kHz	50 kHz	50 kHz	70 kHz	70 kHz	140 kHz	140 kHz
Pixel Depths	Selectable 8 bit, 10 bit, or 12 bit							
Video Output Format (taps)*	2/4	2/3/4/6/8	2/4/8	2/3/4/6/8	2/4/8	2/3/4/6/8	2/4/8	2/3/4/6/8
Synchronization	Via external signal or free run							
Exposure Control	Edge-controlled, level controlled, or programmable							
<b>Mechanical / Electrical</b>								
Housing Size (L x W x H)	48 mm x 87 mm x 62 mm							
Housing Temperature	Up to 50 °C							
Lens Mount	F-mount, M42							
Power Requirements	12 VDC (±10%), max. 10.0 W @ 12 VDC							
Weight (typical)	360 g (without F-Mount adapter)							
Conformity	CE, FCC, RoHS							

# TECHNICAL DETAILS



## Specifications

Basler sprint	spL8192-39kc	spL8192-39kcCI**	spL8192-50km	spL8192-70km
<b>Camera</b>				
Sensor Size (pixels per line)	8192			
Sensor Type	Dual Line CMOS			
Mono / Color	Color	Color	Mono	Mono
Pixel Size	10 μm x 10 μm			
Camera Link Pixel Clock*	40/80 MHz			
Max. Data Speed	640 MHz			
Max. Line Rate	38.6 kHz	38.6 kHz	50 kHz	70 kHz
Pixel Depths	Selectable 8 bit, 10 bit, or 12 bit			
Video Output Format (taps)*	2/3/4/6/8	2/3/4/6/8	2/4/8	2/4/8
Synchronization	Via external signal or free run			
Exposure Control	Edge-controlled, level controlled, or programmable			
<b>Mechanical / Electrical</b>				
Housing Size (L x W x H)	49 mm x 102 mm x 102 mm			
Housing Temperature	Up to 50 °C			
Lens Mount Adapter Interface	V-92 mount for specific lens mount adapter			
Lens Mount Adapter	Unifoc 100/95/V-Basler helical mount, M58 x 0.75/V-Basler lens mount			
Power Requirements	12 VDC (±10%), max. 13.5 W @ 12 VDC			
Weight (typical)	580 g			
Conformity	CE, FCC, RoHS			

# OVERVIEW

## sprint Housing Concept

Another important characteristic of Basler's sprint series is the innovative housing and cooling concept. The sensor module and the camera housing have been integrated as a single unit to optimize cooling and to reduce heat induced noise to a minimum. The sensor and the electronics that control the sensor are part of a ceramic module. The ceramic module is directly attached (both physically and thermally) to a heat sink system that pipes heat directly to the outside of the camera.

To achieve the smallest possible tolerances in six directions, the sensor is positioned in the camera by a specially designed automatic positioning tool (see the graphic showing the up, down, left, right, rotate, and tilt directions). Maintaining the very small tolerances helps to ensure that each camera behaves in the same way. It also makes it easier for users to adjust the sprint to their application and to have a sharp focus over the entire sensor surface.

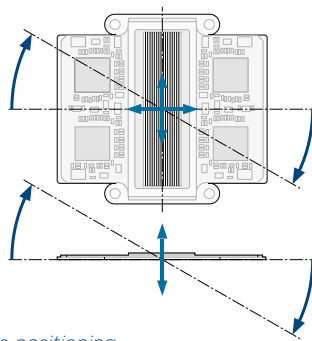

Sensor module positioning

## Camera Link® Interface

Camera Link is a camera communications interface designed for vision applications in science and industry. Camera Link was first established in 2000 by Basler and other leading companies in the machine vision arena. Camera Link enables a maximum data transmission rate of up to 800 MB per second depending on the configuration. The Camera Link interface is used to connect a camera to a compatible frame grabber in a host PC. The frame grabber collects and evaluates data from the camera.

The most important benefits offered by Camera Link are:

- An accepted and proven communications standard for vision technologies (cameras and frame grabbers)
- A simple, standardized cable concept
- Particularly suitable for high data rates
- Standardized protocols for several types of image data transfer, for example, 2, 4, or 8 tap camera output and 8 bit, 10 bit, or 12 bit pixel depth
- Serial communications to the camera via a port on the frame grabber

One main advantage of the Camera Link standard is that numerous frame grabbers produced by many different vendors are compatible with the Basler sprint series.

## Typical Applications

Basler sprint cameras are perfect for use in applications such as:

- OCT (Optical Coherence Tomography)
- Print inspection
- Web inspection of paper, foil, wood veneers, etc.
- Document scanning and postal sorting
- Food inspection
- Surface inspection of printed circuit boards, flat panels and displays, semiconductors, etc.

## OTHER INFORMATION

### How Does Basler Measure and Define Image Quality?



Basler is leading the effort to standardize image quality and sensitivity measurement for cameras and sensors. We are giving the EMVA 1288 standard our strongest support because it describes a unified method to measure, compute, and present the specification parameters for cameras and image sensors. Our cameras are characterized and measured in 100% compliance with the EMVA 1288 standard. Measurement reports can be downloaded from our website.

### How Does Basler Ensure Superior Quality and Reliable High Performance?

Our approach to quality assurance is rigorous: we continually audit all facets of our business to guarantee performance, increase efficiency and reduce costs for our customers. We are compliant with all major quality standards including ISO 9001, CE, RoHS, and more. To ensure consistently high product quality, we employ several quality inspection procedures during manufacturing.

Every Basler camera is subjected to exhaustive optical and mechanical tests before leaving the factory. We have developed a unique combination of optics, hardware, and software tools that can quickly and efficiently calibrate a camera and measure its performance against a set of standard performance criteria. Regardless of what technology or camera model you choose you can be assured of consistent performance.

### 3-Year Warranty

Basler offers a 3-year warranty for their cameras and Basler Lenses. We make this unprecedented promise because we have unparalleled confidence in our products. We continually reinvest in research, development and superior manufacturing capabilities so that our customers can fully rely on the products we manufacture.

### About Basler

Founded in 1988, Basler is a leading global manufacturer of high quality digital cameras and lenses for factory automation, medical & life sciences, retail and traffic applications. The company employs 500 people at its headquarters in Ahrensburg, Germany and subsidiaries in the United States and Asia.

Basler's portfolio of products offers customers the vision industry's widest selection of industrial and network cameras as well as lenses. Today it includes some 300 camera models – and it's still growing. We're committed to developing technology that drives business results for our customers: cameras and lenses that are easy to use, easy to integrate, and deliver an exceptional price/performance ratio.



©Basler AG, No. 12, 09/2016  
ID 2000030041



Phone +66 87 803 1661 | [www.imRNAsia.com](http://www.imRNAsia.com) | [sale@imRNAsia.com](mailto:sale@imRNAsia.com)

