

MV-CH1010-10CM-M72-NF

101 MP CMOS Camera Link Area Scan Camera



GEN*i*CAM



Introduction

MV-CH1010-10CM-M72-NF camera adopts Sony® IMX461 sensor to provide high-quality image. It uses Camera Link interface to transmit non-compressed images in real time, and its max. frame rate can reach 8 fps in full resolution.

Key Feature

- Adopts rolling shutter CMOS sensor providing wide dynamic range and high-quality image.
- Supports configuration modes of Base, Medium, Full and 80-bit via the Camera Link interface.
- Adopts compact design with mounting holes for flexible mounting.
- Compatible with Camera Link V2.0 Protocol, GenICam Standard, and the third-party software based on the protocol and standard.

Available Model

MV-CH1010-10CM-M72-NF

Applicable Industry

FPD, electronics and semiconductor inspection, research and scientific imaging, microscopy and metrology, etc.

Sensor Quantum Efficiency

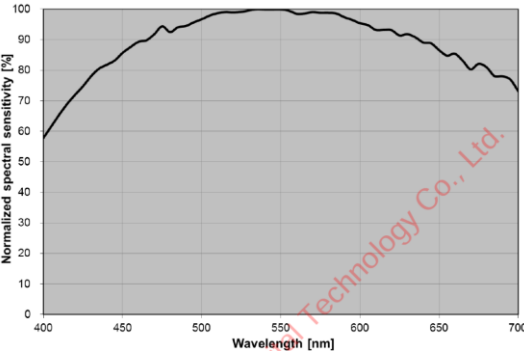

Dimension

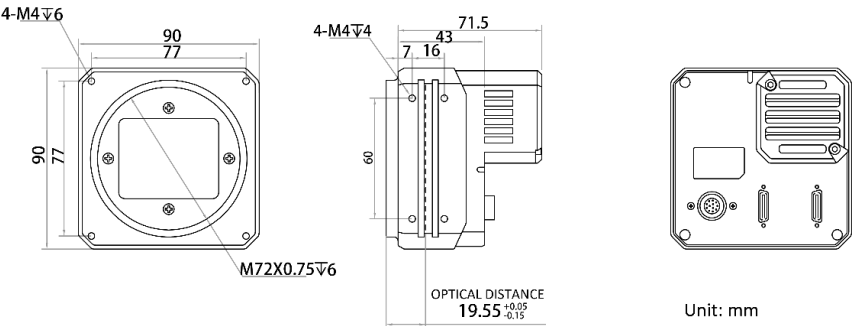

Specification

Model	MV-CH1010-10CM-M72-NF			
Camera				
Sensor type	CMOS, rolling shutter			
Sensor model	Sony® IMX461			
Pixel size	3.76 μm × 3.76 μm			
Sensor size	55 mm			
Resolution	11648 × 8740		11520 × 8740	
Configuration mode	Base	Medium	Full	80-bit
Tap geometry	2X_1Y	4X_1Y	8X_1Y	10X_1Y
Tap number	2 Taps	4 Taps	8 Taps	10 Taps
Max. frame rate	8 fps @11520 × 8740 Mono 8			
Pixel clock	40 MHz, 60 MHz, 70 MHz, 85 MHz			
Dynamic range	78 dB			
SNR	45 dB			
Gain	0 dB to 36 dB			
Exposure time	14 μs to 10 sec			
Mono/color	Mono			
Pixel format	ADC 12-bit mode: Mono 8/10/12; ADC 16-bit mode: Mono 8/10/12/16			
Exposure mode	Off/Once/Continuous exposure mode, supports global reset			
Binning	Supports 1 × 1, 1 × 2, 1 × 4, 2 × 1, 2 × 2, 2 × 4, 4 × 1, 4 × 2, 4 × 4			
Decimation	Supports 1 × 1, 1 × 2, 1 × 4, 2 × 1, 2 × 2, 2 × 4, 4 × 1, 4 × 2, 4 × 4			
Reverse image	Supports horizontal reverse image output			
Electrical feature				
Data interface	Camera Link with SDR interface			
Digital I/O	12-pin Hirose connector provides power and I/O, including opto-isolated input × 1 (Line 0), opto-isolated output × 1 (Line 1), bi-directional non-isolated I/O × 1 (Line 2), and RS-232 × 1.			
Power supply	12 VDC to 24 VDC			
Power consumption	Typ. 14 W@24 VDC			
Mechanical				
Lens mount	M72*0.75, optical back focal length 19.55 mm (0.8")			
Dimension	90 mm × 90 mm × 71.5 mm (3.5" × 3.5" × 2.8")			
Weight	Approx. 790 g (1.7 lb.)			
Ingress protection	IP40 (under proper lens installation and wiring)			
Temperature	Working temperature: 0 °C to 50 °C (32 °F to 122 °F) Storage temperature: -30 °C to 70 °C (-22 °F to 158 °F)			
Humidity	20% to 95% RH, non-condensing			
General				
Client software	MVS or frame grabber software meeting with GenICam Protocol			
Operating system	32/64-bit Windows 7/10			
Compatibility	Camera Link V2.0, GenICam			
Certification	CE, FCC, RoHS, KC			