

CSCLV90BC3

CSCV90BC3/CSCV125BC3/CSCV125CC3

CSCX30BC3/CSCS60BM18/CSCS20BC2



Outline

Cameras with CameraLink interface.

Suitable for setting in equipment with compact size of 20mm cubic or 29mm cubic, and also light weight for 0.3M to 1.4M. Wide product range for frame rate of 0.3M 4 times speed 125 fps, 1.3M 60fps etc.

Features

Easy operation

- Powered by frame grabber board complying PoCL.
- Capturing image with no deterioration in horizontal resolution by scanning all pixels.
- Selectable connecting direction of cable for CSCLV90BC3.
- High accuracy of optical axes is guaranteed for CSCS60BM18.

Various function

- Higher speed image capturing is achieved by partial scanning function.
- CSCS60BM18 has finer image processing functions.
 - Sequential shutter mode allows setting different condition of imaging and output.
 - Inverse function (horizontal / vertical)

Dimensions

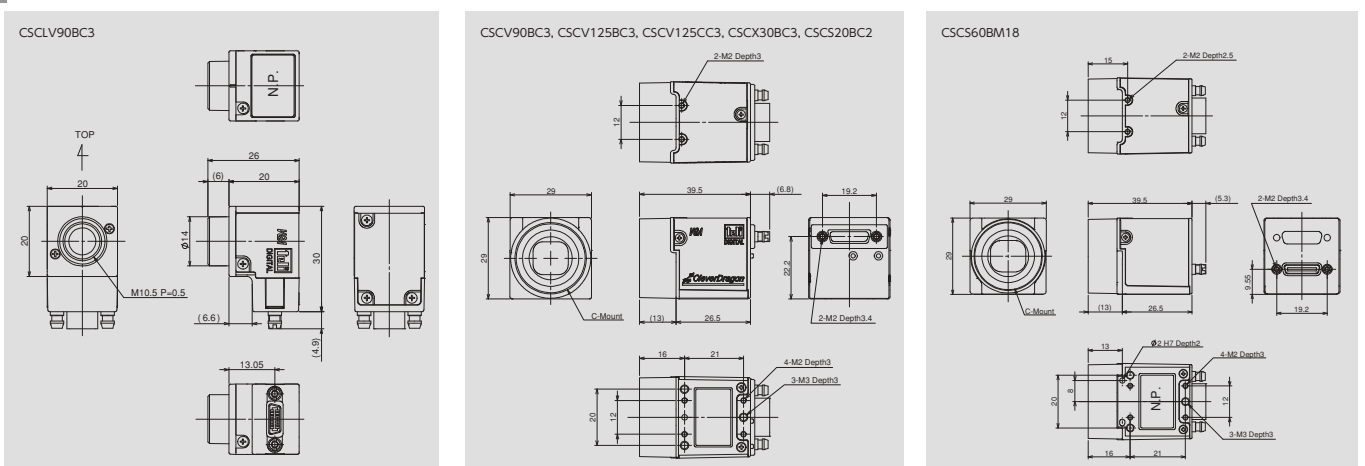

CSCU15BC18/CSCU30BC18/CSCU30CC18 CSCQS15BC23/CSCQS15CC23



Outline

With CameraLink interface.

Both of 2M and 5M have CCD. Choice of 2M 1/1.8 type 15 /30 fps and 5M 2/3 type 15 fps.

Features

Easy operation

- Powered by frame grabber board based on PoCL (CSCU15BC18/CSCU30CC18)

Various function

- Higher speed image scanning with partial scanning function.
- CSCS60BM18 has smoother image processing function.
 - By high speed draft scanning mode, CSCU15BC18 scans 4 lines among 16 lines, and CSCU30BC/CSCU30CC18 scans 2 lines among 8 lines.
- CSCU30BC18/CSCU30CC18/CSCQS15BC23/CSCQS15CC23
 - With multiple shutter function, image can be scan at any time and stocked image can be output at any time by trigger signal from outside.

Dimensions

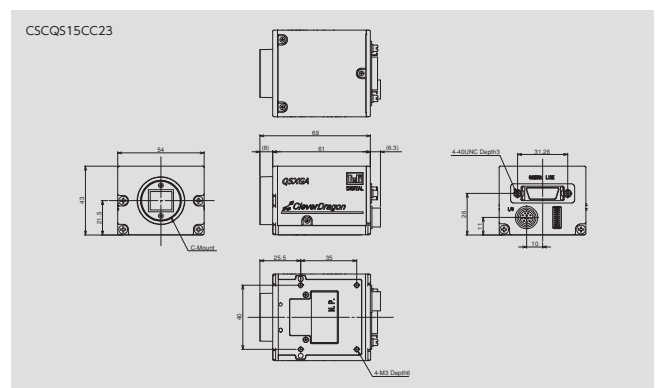
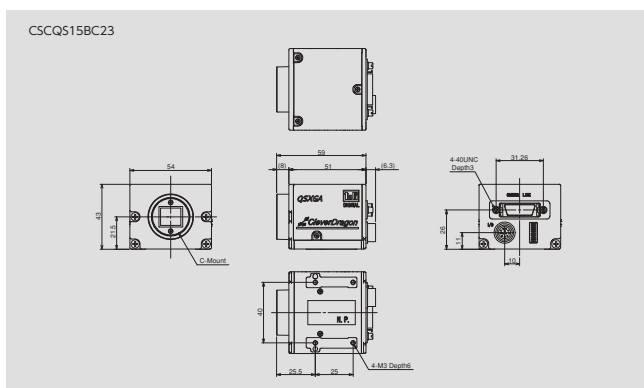
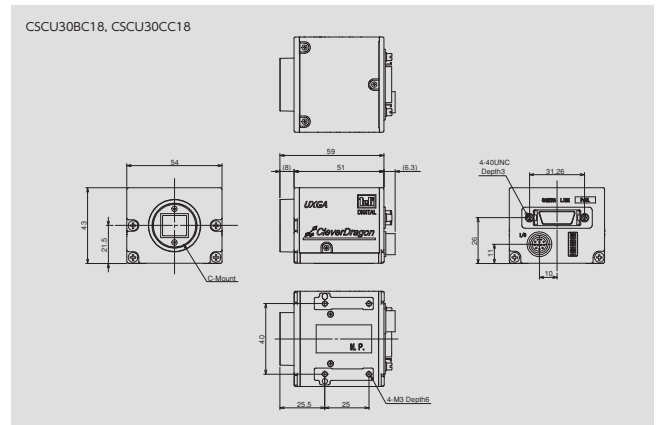
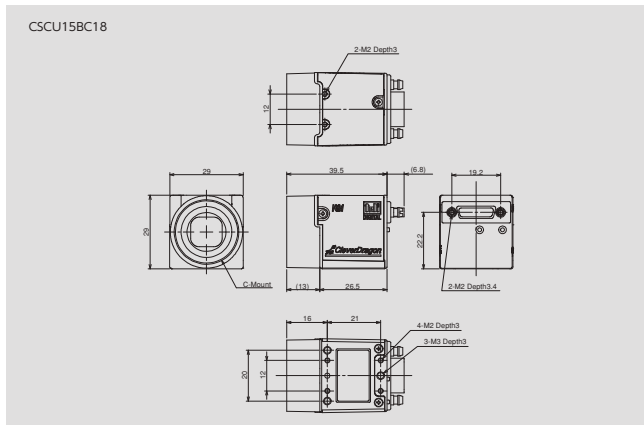

CSC6M100BMP11/CSC6M100CMP11 CSC12M25BMP19-01B/CSC12M25CMP19



CSC6M100BMP11 / CSC6M100CMP11

CSC12M25BMP19-01B / CSC12M25CMP19

Outline

With CameraLink interface.

Both of 6.5M(1.1 type 6.55M pixel 99 fps) and 12M(1.9 type 12.58M pixel 25 fps) are suitable for high speed image processing with CMOS sensor originally developed by TELL. 3 years warranty. Smoother image processing is achieved by TELL original functions.

Features

Easy operation

- Clear image with less camera shake as CCD is achieved by global electronic shutter.
- Both of 6.5M and 12M achieve accurate optical axes.

Various function

- Functions for efficient image processing
 - Any partial area in vertical or horizontal can be scanned with WOI function.
 - 2 (H) x 2 (V) or 4 (H) x 4 (V) can be scan as 1 pixel without changing viewing direction by binning function.
 - Higher speed scanning can be achieved by using WOI functions and binning function at the same time.
- CSC6M100BMP11 / CSC6M100CMP11
 - Inverse pixel (horizontal / vertical) function
- CSC12M25BMP19-01B / CSC12M25CMP19
 - Optimum lens can be selectable to 1.9 type 12.58M pixel image sensor by TFL-II Mount.

Dimensions

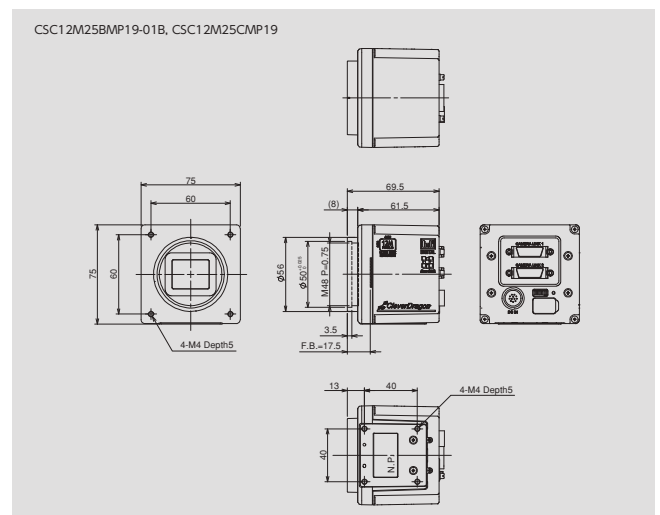
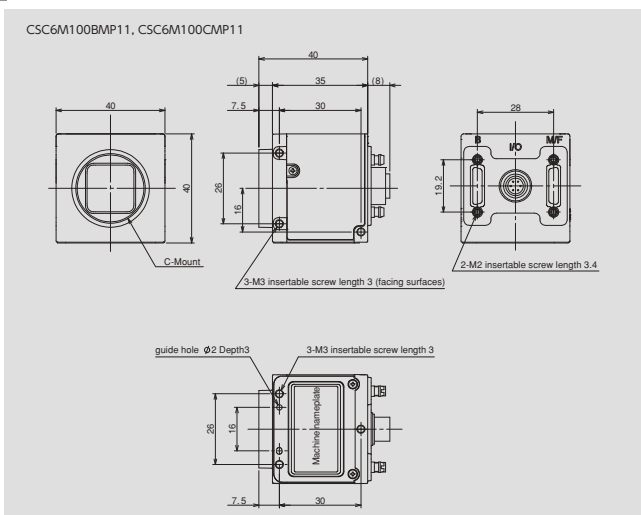

Specifications

B/W / COLOR	B/W					
Item	0.3M		0.8M	1.3M	1.4M	
Model Name	CSCVL90BC3	CSCV90BC3	CSCV125BC3	CSCX30BC3	CSCS60BM18	CSCS20BC2
Interface	CameraLink (PoCL-Lite)			CameraLink (PoCL)		
Imager	1/3 type CCD (ICX424AL)			1/3 type CCD (ICX204AL)	1/1.8 type GS-CMOS (EV76C560ABT)	1/2 type CCD (ICX267AL)
Resolution	648(H) × 494(V)			1,024(H) × 768(V)	1,280(H) × 1,024(V)	1,360(H) × 1,024(V)
Frame Rate	90 fps	92.4 fps	126.2 fps	22.99 fps	61 fps	19.5 fps
Pixel Size	7.4(H) × 7.4(V) μm			4.65(H) × 4.65(V) μm	5.3(H) × 5.3(V) μm	4.65(H) × 4.65(V) μm
Electronic Shutter	1/20,000 to 8 s, Random Trigger Shutter		1/100,000 to 8 s, Random Trigger Shutter	1/20,000 to 8 s, Random Trigger Shutter	1/100,000 to 1 s, Random Trigger Shutter	1/20,000 to 2 s, Random Trigger Shutter
Scan Method	Progressive					
Scanning Frequency	Horizontal: 46.2 kHz Vertical: 92.6 Hz (Maximum Speed with Normal Shutter) Pixel Clock Frequency: 36 MHz (1CLK) ± 100 ppm	Horizontal: 46.153 kHz Vertical: 92.4 Hz (Maximum Speed with Normal Shutter) Pixel Clock Frequency: 36.000 MHz (1CLK) ± 100 ppm	Horizontal: 62.937 kHz Vertical: 126.26 Hz (Maximum Speed with Normal Shutter) Pixel Clock Frequency: 49.090902 MHz (1CLK) ± 100 ppm	Horizontal: 23.22 kHz Vertical: 29.99 Hz (Maximum Speed with Normal Shutter) Pixel Clock Frequency: 29.50 MHz (1CLK) ± 100 ppm	Horizontal: 63.776 kHz Vertical: 61.25 Hz (Maximum Speed with Normal Shutter) Pixel Clock Frequency: 50 MHz (1CLK)	Horizontal: 20.11 kHz Vertical: 19.49 Hz (Maximum Speed with Normal Shutter) Pixel Clock Frequency: 36.00 MHz (1CLK) ± 100 ppm
Color Filter	—					
Standard Sensitivity	600 lx, F5.6 (FIX Gain)		850 lx, F5.6 (FIX Gain)	400 lx, F5.6	500 lx, F5.6	
Minimum Sensitivity	6 lx, F1.4 (Gain 10 dB, Video Level 50%)		8 lx, F1.4 (Gain 10 dB, Video Level 50%)	4 lx, F1.4 (Gain 10 dB, Video Level 50%)	2.6 lx, F1.4 (Gain MAX, Video Level 50%)	5 lx, F1.4 (Gain 10 dB, Video Level 50%)
Gamma	γ=1.0					
Gain	MANUAL 0 to approx. +12 dB (1 step = Approx. 0.132 dB)		MANUAL -6 to approx. +18 dB (1 step = Approx. 0.1 dB)	MANUAL 0 to approx. +12 dB (1 step = Approx. 0.132 dB)	MANUAL Analog: x1 / x1.5 / x2 / x3 Digital: 0 to approx. +6 dB (1 step = Approx. 0.1 dB)	MANUAL 0 to approx. +12 dB (1 step = Approx. 0.132 dB)
White Balance	—					
Sync System	Internal synchronization					
Image Output Format	Data: 10 / 8 bit Switching All pixel readout: 648 (H) × 494 (V) [Approx. 90 fps] Partial Scan: 648 (H) × 120 to 494 (V) [Approx. 95 to 290 fps] minimum lines: 120, minimum step: 1 line	Data: 10 / 8 bit Switching All pixel readout: 648 (H) × 494 (V) [Approx. 92.4 fps] Partial Scan: 648 (H) × 120 to 480 (V) [Approx. 94.8 to 293.9 fps] minimum lines: 120, minimum step: 1 line	Data: 10 / 8 bit Switching All pixel readout: 648(H) × 494(V) [Approx. 126.2 fps] Partial Scan: 648(H) × 120 to 480(V) [Approx. 129.5 to 395.8 fps] minimum lines: 120, minimum step: 1 line	Data: 10 / 8 bit Switching All pixel readout: 1,024 (H) × 768 (V) [Approx. 29.99 fps] Partial Scan: 1,024 (H) × 192 to 384 (V) [Approx. 52.75 to 85.14 fps] minimum lines: 192, minimum step: 1 line	All pixel readout: 1,280 (H) × 1,024 (V) [Approx. 61 fps] Scalable: minimum area 64(H) × 64(V)	Data: 10 / 8 bit Switching All pixel readout: 1,360(H) × 1,024(V) [Approx. 19.5 fps] Partial Scan: 1,360(H) × 512 to 768(V) [Approx. 25.0 to 34.8 fps] minimum lines: 512, minimum step: 1 line
Power Supply	DC12 V ± 10%					
Power Consumption	Approx. 1.4 W	Approx. 1.6 W	Approx. 1.8 W	Approx. 1.3 W	Approx. 0.96 W	Approx. 1.8 W
Lens Mount	M10.5 P0.5 (female)			C - Mount		
Dimensions	20 (W) × 20 (H) × 20 (D) mm (Not including protrusion)			29 (W) × 29 (H) × 26.5 (D) mm (Not including protrusion)		
Weight	Approx. 18 g	Approx. 45 g	Approx. 40 g	Approx. 45 g	Approx. 33 g	Approx. 40 g
Operation Assurance	Temperature: -5°C to 45°C Humidity: 10% to 90% (no condensation)					
Conformity	CE, FCC, RoHS, WEEE					

B/W / COLOR	B/W				
Item	2M		5M	6.5M	12M
Model Name	CSCU15BC18	CSCU30BC18	CSCQS15BC23	CSC6M100BMP11	CSC12M25BMP19-01B
Interface	CameraLink (PoCL)		CameraLink (PoCL / Non PoCL)	CameraLink (PoCL)	CameraLink (Non PoCL)
Imager	1/1.8 type CCD (ICX274AL)		2/3 type CCD (ICX625AL)	1.1 type GS-CMOS (TELI Original)	1.9 type GS-CMOS (TELI Original)
Resolution	1,616(H) × 1,200(V)	1,628(H) × 1,236(V)	2,456(H) × 2,058(V)	2,560(H) × 2,560(V)	4,096(H) × 3,072(V)
Frame Rate	15.0 fps	30 fps	15 fps	99.2 fps	25 fps
Pixel Size	4.40(H) × 4.40(V) μm		3.45(H) × 3.45(V) μm	5.0(H) × 5.0(V) μm	6(H) × 6(V) μm
Electronic Shutter	1/20,000 to 2 s, Random Trigger Shutter	1/65,934 to 1/30 s, Random Trigger Shutter	1/20,000 to 2 s, Random Trigger Shutter	1/100,000 to 1/5 s, Random Trigger Shutter	1/20,000 to 2 s, Random Trigger Shutter
Scan Method	Progressive				
Scanning Frequency	Horizontal: 18.75 kHz Vertical: 15.48 Hz (Maximum Speed with Normal Shutter) Pixel Clock Frequency: 36.00 MHz (1CLK) ± 100 ppm	Horizontal: 37.500 kHz Vertical: 30.000 Hz Pixel Clock Frequency: 72.000 MHz	Horizontal: 31.185 kHz Vertical: 15.104 Hz Pixel Clock Frequency: 60.000 MHz	Pixel Clock Frequency: 84, 72, 60 MHz	Horizontal: 75 kHz Vertical: 25 Hz Medium Configuration, 10 bit, when Shutter OFF
Color Filter	—				
Standard Sensitivity	200 lx, F5.6	600 lx, F5.6	400 lx, F5.6	900 lx, F5.6 (Exposure Time 1/60 s)	2,000 lx, F5.6
Minimum Sensitivity	2 lx, F1.4 (Gain 10 dB, Video Level 50%)	6 lx, F1.4 (Gain MAX, Video Level 50%)	6.25 lx, F1.4 (Gain MAX, Video Level 50%)	8 lx, F2.8 (Gain MAX, Exposure Time 1/60 s, Video Level 50%)	30 lx, F2.8 (Gain MAX, Video Level 50%)
Gamma	γ=1.0				
Gain	MANUAL 0 to approx. +12 dB (1 step = Approx. 0.132 dB)	MANUAL 0 to +12 dB (150 Steps)	MANUAL 0 to +12 dB (121 Steps)	MANUAL 0 to approx. +18 dB (1 step = Approx. 0.1 dB)	MANUAL 0 to +18 dB (180 Steps)
White Balance	—				
Sync System	Internal synchronization				
Image Output Format	Data: 10 / 8 bit Switching All pixel readout: 1,616 (H) × 1,200 (V) [Approx. 15.0 fps] Partial Scan: 1,616 (H) × 600 to 900 (V) [Approx. 19.9 to 27.8 fps] minimum lines: 600, minimum step: 1 line	Data: 12 / 10 / 8 bit Switching All pixel readout: 1,616 (H) × 1,200 (V) [Approx. 30 fps] Partial Scan: 1,628 (H) × 50 to 1,236 (V) [Approx. 30 to 183 fps] High-speed draft mode: 1,628 (H) × 309 (V) [Approx. 89 fps]	Data: 12 / 10 / 8 bit Switching All pixel readout: 2,456 (H) × 2,058 (V) [Approx. 15 fps] Partial Scan: 2,456 (H) × 100 to 2,058 (V) [Approx. 15 to 52 fps] High-speed draft mode: 2,456 (H) × 257 (V) [Approx. 37.1 fps]	Data: 12 / 10 / 8 bit Switching All pixel readout: 2,560 (H) × 2,560 (V) [Approx. 85 fps] Binning (2×2): 1,280 (H) × 1,280 (V) [Approx. 170 fps] Binning (4×4): 640 (H) × 640 (V) [Approx. 340 fps] WOI / Binning: Depends on the window setting Reverse (H/V) / Rotation (180-degree)	Data: 10 / 8 / ex 8 bit Switching All pixel readout: 4,096 (H) × 3,072 (V) [Approx. 25 fps] Binning: 2,048 (H) × 1,536 (V) [Approx. 41.8 fps] Sub sampling: 2×2: 2,048 (H) × 1,536 (V) [Approx. 50 fps] 4×4: 1,024 (H) × 768 (V) [Approx. 100 fps] 8×8: 512 (H) × 384 (V) [Approx. 200 fps]
Power Supply	DC12 V ± 10%				
Power Consumption	Approx. 1.8 W	Approx. 3.5 W	Approx. 4 W	Approx. 3.84 W	Approx. 5.4 W
Lens Mount	C - Mount				TFL-II Mount F-Mount lens can be used by FTAR-2 (as optional accessory) mount conversion adaptor.
Dimensions	29 (W) × 29 (H) × 26.5 (D) mm (Not including protrusion)	54(W) × 43(H) × 51(D) mm (Not including protrusion)		40 (W) × 40 (H) × 35 (D) mm (Not including protrusion)	75 (W) × 75 (H) × 69.5 (D) mm (Not including protrusion)
Weight	Approx. 40 g	Approx. 170 g	Approx. 180 g	Approx. 100 g	Approx. 450 g
Operation Assurance	Temperature: -5°C to 45°C Humidity: 10% to 90% (no condensation)				
Conformity	CE, FCC, RoHS, WEEE				

* GS-CMOS : Global Shutter type CMOS image sensor.

Specifications

B/W / COLOR	COLOR				
Pixels	0.3M	2M	5M	6.5M	12M
Item / Model Name	CSCV125CC3	CSCU30CC18	CSCQ515CC23	CSC6M100CMP11	CSC12M25CMP19
Interface	CameraLink (PoCL)		CameraLink (PoCL / Non PoCL)	CameraLink (PoCL)	CameraLink (Non PoCL)
Imager	1/3 type CCD (ICX424AQ)	1/1.8 type CCD (ICX274AQ)	2/3 type CCD (ICX625AQ)	1.1 type GS-CMOS (TELI Original)	1.9 type GS-CMOS (TELI Original)
Resolution	640(H) × 480(V)	1,628(H) × 1,236(V)	2,448(H) × 2,058(V)	2,560(H) × 2,560(V)	4,096(H) × 3,072(V)
Frame Rate	127.7 fps	30 fps	15.1 fps	99.2 fps	25 fps
Pixel Size	7.4(H) × 7.4(V) μm	4.40(H) × 4.40(V) μm	3.45(H) × 3.45(V) μm	5.0(H) × 5.0(V) μm	6(H) × 6(V) μm
Electronic Shutter	1/100,000 to 8 s, Random Trigger Shutter	1/65,934 to 1/30 s, Random Trigger Shutter	1/20,000 to 2 s, Random Trigger Shutter	1/100,000 to 1/5 s, Random Trigger Shutter	1/20,000 to 2 s, Random Trigger Shutter
Scan Method	Progressive				
Scanning Frequency	Horizontal : 62.937 kHz Vertical : 126.26 Hz (Maximum Speed with Normal Shutter) Pixel Clock Frequency : 49.090902 MHz (1CLK) ± 100 ppm	Horizontal : 37.500 kHz Vertical : 30.000 Hz Pixel Clock Frequency : 72.000 MHz	Horizontal : 31.18 kHz Vertical : 15.09 Hz Pixel Clock Frequency : 80.000 MHz	Pixel Clock Frequency : 84, 72, 60 MHz	Horizontal : 78.4 kHz Vertical : 25 Hz Medium Configuration, 10 bit, when Shutter OFF
Color Filter	RGB primary color mosaic-on-tip color filter				
Standard Sensitivity	2,400 lx, F5.6 (FIX Gain)	2,400 lx, F8	1,800 lx, F8	2,500 lx, F5.6 (Exposure Time 1/60 s)	3,000 lx, F4
Minimum Sensitivity	20 lx, F1.4 (Gain 18 dB, Video Level 50%)	35 lx, F1.4 (Gain MAX, Video Level 50%)	14 lx, F1.4 (Gain MAX, Video Level 50%)	20 lx, F2.8 (Gain MAX, Exposure Time 1/60 s, Video Level 50%)	125 lx, F2.8 (Gain MAX, Video Level 50%)
Gamma	ON / OFF switching [Factory setting: OFF] * Disabled when RAW Data Output (8 / 10 bit) (OFF)	ON (Equivalent to 0.65) / OFF (γ=1) Switching		γ=1.0, 16 Steps Preset, or LUT	γ=1.0
Gain	MANUAL -6 to approx. +18 dB (1 Step = Approx. 0.1 dB)	MANUAL 0 to +6 dB (76 Steps)	MANUAL 0 to +6 dB (61 Steps)	Analog: 0 / +3 / +6 / +9 dB switching Digital: 0 to +18 dB (180 steps, 1 step = 0.1 dB)	MANUAL 0 to +18 dB (180 Steps)
White Balance	MANUAL or OPWB (*OPWB only works at RGB 24 bit)	MWB, OPWB			
Sync System	Internal synchronization				
Image Output Format	Data : RGB 24 bit, RAW 10 bit, RAW 8 bit Switching All pixel readout : 640 (H) × 480 (V) [Approx. 127.7 fps] Partial Scan : 640 (H) × 120 to 480 (V) [Approx. 127.7 to 378.6 fps] minimum lines : 120, minimum step : 2 line	Data : RGB 24 bit / RAW (12 / 10 / 8 bit) Switching All pixel readout : 1,628 (H) × 1,236 (V) [Approx. 30 fps] Partial Scan : 1,628 (H) × 50 to 1,236 (V) [Approx. 30 to 183 fps] High-speed draft mode : 1,628 (H) × 309 (V) [Approx. 89 fps]	Data : RGB 24 bit / RAW (12 / 10 / 8bit) Switching All pixel readout : 2,448 (H) × 2,058 (V) [Approx. 15.1 fps] Partial Scan : 2,448 (H) × 100 to 2,058 (V) [Approx. 15.1 to 52.3 fps] High-speed draft mode : RGB 2,448 (H) × 253 (V), RAW 2,448 (H) × 254 (V) [Approx. 37.2 fps]	Data : 12 / 10 / 8 bit Switching All pixel readout : 2,560 (H) × 2,560 (V) [Approx. 85 fps] Binning (2×2) : 1,280 (H) × 1,280 (V) [Approx. 170 fps] Binning (4×4) : 640 (H) × 640 (V) [Approx. 340 fps] WOI / Binning : Depends on the window setting Reverse (H/V) / Rotation (180-degree)	Data : RAW 10 bit / RAW 8 bit / ex8 bit Switching All pixel readout : 4,096(H) × 3,072(V) [Approx. 25 fps] (Medium Configuration, 10 bit, Shutter OFF)
Power Supply	DC12 V ± 10%				
Power Consumption	Approx. 1.8 W	Approx. 4.5 W	Approx. 4.9 W	Approx. 3.84 W	Approx. 5.4 W
Lens Mount	C - Mount				TFL-II Mount F-Mount lens can be used by FTAR-2 (as optional accessory) mount conversion adaptor.
Dimensions	29 (W) × 29 (H) × 26.5 (D) mm (Not including protrusion)	54(W) × 43(H) × 51(D) mm (Not including protrusion)	54 (W) × 43 (H) × 61 (D) mm (Not including protrusion)	40 (W) × 40 (H) × 35 (D) mm (Not including protrusion)	75 (W) × 75 (H) × 69.5 (D) mm (Not including protrusion)
Weight	Approx. 40 g	Approx. 175 g	Approx. 190 g	Approx. 100 g	Approx. 450 g
Operation Assurance	Temperature: -5°C to 45°C Humidity: 10% to 90% (no condensation)				
Conformity	CE, FCC, RoHS, WEEE				

* GS-CMOS : Global Shutter type CMOS image sensor. CSC12M25CMP19, and CSC12M25BMP19 are approved KC directive.

Accessory information (options)

- PoCL Lite cable ,CameraLink cable ▶ P29
- C-Mount lens, lens ▶ P32 ~ 34
- M10.5P0.5 female screw ▶ P35
- TFL-II Mount lens ▶ P35
- F-Mount conversion adopter (FTAR-2)
⇒For details, please contact our staff.
- Tripod attachment ▶ P30
- Applied grabber board ▶ P40
 - Spectral response ▶ P23, 24
 - pin assignment ▶ P25