

Standard Telecentric Lens

| Model | | APT1.5-65 | | | |
|--------------------------------|--------|--------------------------------|---|-----|----|
| Optical Mag. | | × 1.5 ± 5 % | | | |
| FOV (V x H) | 1/1.8" | 3.6 | × | 4.7 | mm |
| | 1/2" | 3.2 | × | 4.3 | mm |
| | 1/3" | 2.4 | × | 3.2 | mm |
| WD | | 68.9 mm ± 2.1 | | | |
| O/I (Object & Imager Distance) | | 142.6 mm | | | |
| Working F/# | | 25.0 | | | |
| NA | | 0.030 | | | |
| DOF at PCoC ϕ 0.04mm | | 0.9 mm | | | |
| TV Distortion (1/1.8") | | 0.02 % | | | |
| Wavelength | | Visible | | | |
| Mount | | C-Mount | | | |
| Flange Back | | 17.526 mm | | | |
| Sensor Size (max.) | | 1/1.8" | | | |
| Co-Axial Prism | | - | | | |
| Weight (approx.) | | 33 g | | | |
| Dimension | | ϕ 29 (max.) × L = 56.2 mm | | | |

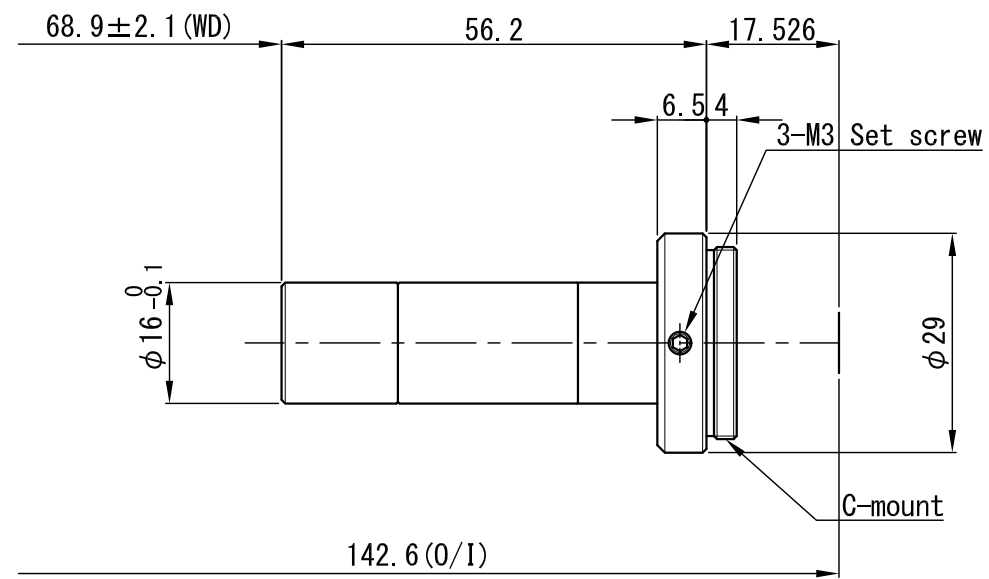

| | | | | | | | | | | | |
|---|------|----------|---------------|----------|---------|------------------------|----------------------|-----------------|-----------|-----------------|-------------|
| △ | | | | APPROVED | CHECKED | MATERIAL 材料 | - | CHAMFER 一般面取 | - | QUANTITY 個数 | |
| △ | | | | T. A. | T. A. | TREATMENT 処理 | - | FINISHING 仕上 | - | - | |
| △ | | | | | | TREATMENT CONTACT 処理接点 | - | DECENTRATION 偏芯 | - | | |
| △ | | | | DESIGNED | DRAWN | OVER 250 UP TO 1000 | ±0.3 ±0.5 ±1.0 ±0.2 | ANGLE 角度 | METHOD 図法 | REMARK 適用 (機種名) | |
| △ | | | | T. A. | S. K. | OVER 63 UP TO 250 | ±0.2 ±0.3 ±0.6 ±0.15 | UNIT (mm) | - | APT 1.5-65 | |
| △ | | | | | | OVER 16 UP TO 63 | ±0.1 ±0.2 ±0.4 ±0.1 | SCALE | 1 / 1 | | NAME |
| | DATE | EXCH NO. | REVISION 変更記事 | | | TOLERANCES | Ⓐ B C S | DATE | '14.03.12 | DRAW NO. | 01DTC0535A1 |