

Standard Telecentric Lens

Model		APT2-65			
Optical Mag.		× 2.0 ± 5 %			
FOV (V x H)	1/1.8"	2.7	×	3.6	mm
	1/2"	2.4	×	3.2	mm
	1/3"	1.8	×	2.4	mm
WD		65.4 mm ± 2			
O/I (Object & Imager Distance)		151.5 mm			
Working F/#		25.0			
NA		0.040			
DOF at PCoC ϕ 0.04mm		0.5 mm			
TV Distortion (1/1.8")		0.00 %			
Wavelength		Visible			
Mount		C-Mount			
Flange Back		17.526 mm			
Sensor Size (max.)		1/1.8"			
Co-Axial Prism		-			
Weight (approx.)		37 g			
Dimension		ϕ 29 (max.) × L = 68.6 mm			

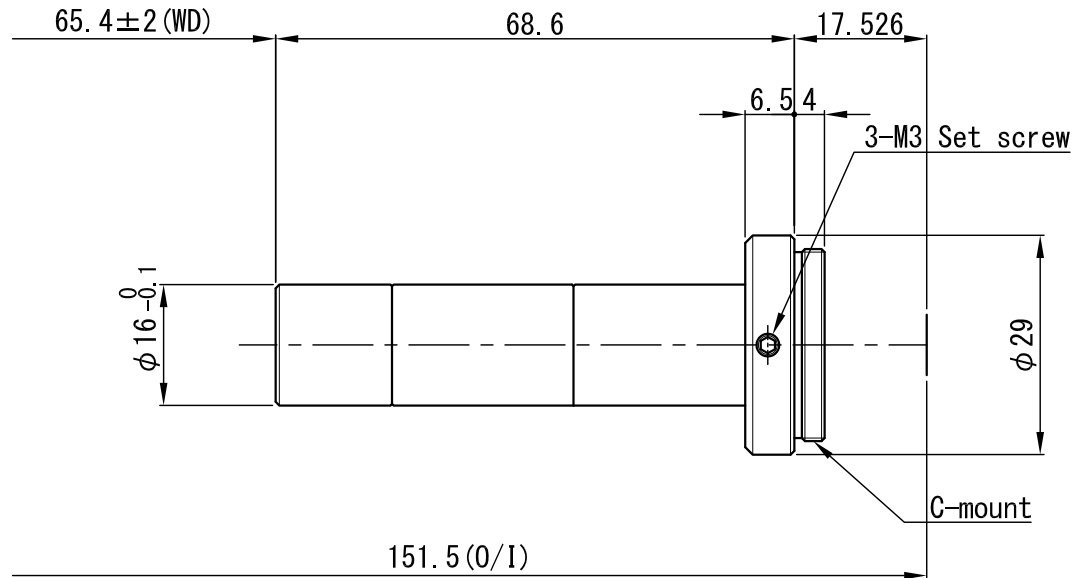

△				APPROVED	CHECKED	MATERIAL 材料	-				CHAMFER 一般面取	-	QUANTITY 個数	
△				T. A.	T. A.	TREATMENT 処理	-				FINISHING 仕上	-	-	
△						TREATMENT CONTACT 処理接点	-				DECENTRATION 偏芯	-		
△				DESIGNED	DRAWN	OVER 250 UP TO 1000	±0.3	±0.5	±1.0	±0.2	UNIT (mm)	ANGLE 角度	METHOD 図法	REMARK 適用 (機種名)
△				T. A.	S. K.	OVER 63 UP TO 250	±0.2	±0.3	±0.6	±0.15		-		A P T 2 - 6 5
△						OVER 16 UP TO 63	±0.1	±0.2	±0.4	±0.1	SCALE	1 / 1	NAME	外 觀 図
	DATE	EXCH NO.	REVISION 変更記事			TOLERANCES	A	B	C	S	DATE	'14.03.12	DRAW NO.	0 D T C 0 5 3 7 A 1