

Model	SV-0813V
Focal Length	8 mm (8.05)
Maximum Aperture Ratio	1:1.3 (1.36)
F.No	F1.3 ~ Close
Angle of view (2/3")	44.6° × 57.3° (Diagonal:68.7°)
M.O.D	0.2 m
Flange back	17.526 mm
Operation of Iris & Focus	Manual
Mount	C-mount
Filter Thread	M25.5 mm P= 0.5
TV distortion (2/3")	-2.13 %
Sensor size (max.)	2/3"
Weight (approx.)	55 g
Dimension	φ 29.5 (MAX) × L= 34 mm

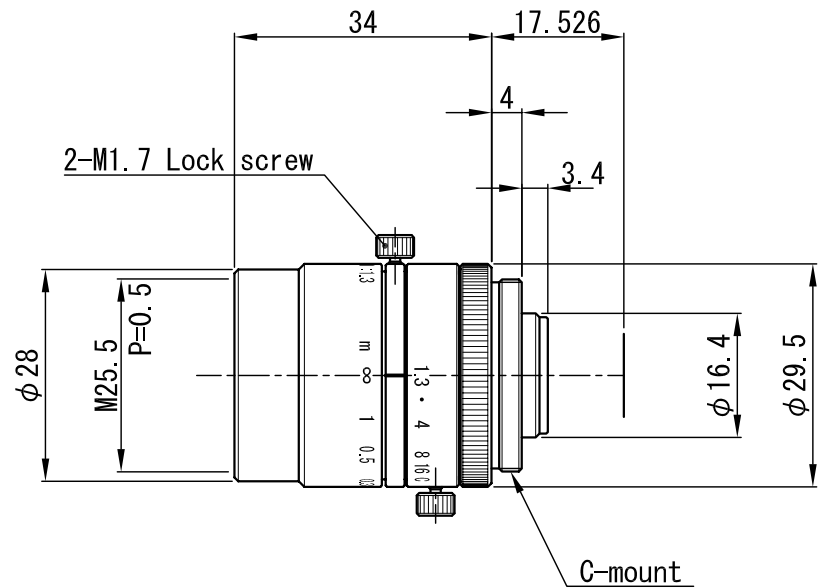

△				APPROVED	CHECKED	MATERIAL 材料	-	CHAMFER 一般面取	-	QUANTITY 個数	
△				T. A.	T. A.	TREATMENT 処理	-	FINISHING 仕上	-	-	
△						TREATMENT CONTACT 処理接点	-	DECENTRATION 偏芯	-		
△				DESIGNED	DRAWN	OVER 250 UP TO 1000	±0.3 ±0.5 ±1.0 ±0.2	ANGLE 角度	METHOD 図法	REMARK 適用 (機種名)	
△				T. A.	T. T.	OVER 63 UP TO 250	±0.2 ±0.3 ±0.6 ±0.15	UNIT (mm)	-	SV-0813V	
△						OVER 16 UP TO 63	±0.1 ±0.2 ±0.4 ±0.1				SCALE
△						OVER 0 UP TO 16	±0.05 ±0.1 ±0.2 ±0.1	DATE	11.04.06	DRAW NO.	01SV0098A1
	DATE	EXCH NO.	REVISION 変更記事			TOLERANCES	Ⓐ B C S				