

Mega Pixel CCTV Lens

| | | | |
|---------------------------|-------------------------|---------|-------------------------|
| Model | SV-3514H | | |
| Focal Length (f) | 35 mm | (35.01) | |
| Maximum Aperture Ratio | 1:1.4 | (1.44) | |
| F/# | 1.4 ~ 16 | | |
| Angle of view (2/3") | 10.8° | X | 14.3° (Diagonal: 18.2°) |
| M.O.D | 200 mm | | |
| Back Focus | 13.81 mm | | |
| Flange back | 17.526 mm | | |
| Operation of Iris & Focus | manual | | |
| Mount | C-mount | | |
| Filter Thread | M 35.5 P= 0.5 | | |
| Front Principle Point | 32.53 mm | | |
| Rear Principle Point | -21.20 mm | | |
| FPP RPP Distance | -13.70 mm | | |
| Optical over all length | 40.03 mm | | |
| Wavelength | Visible (400nm - 700nm) | | |
| TV distortion (2/3") | -0.14 % | | |
| Sensor size (max.) | 2/3" | | |
| Weight (approx.) | 150.0 g | | |
| Dimension | 45.5 mm | | |

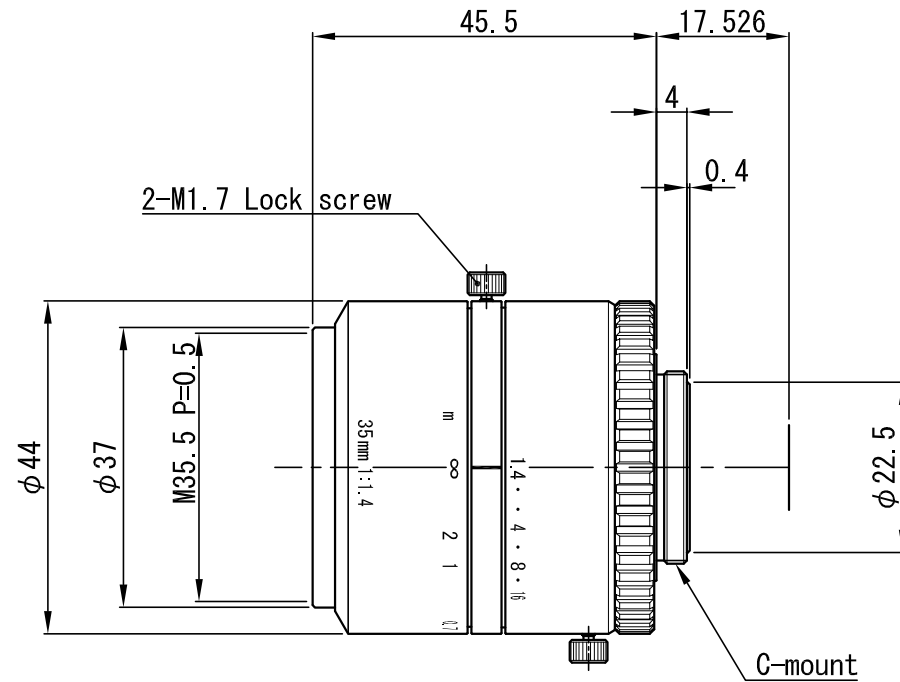

| | | | | | | | | | | | | | | |
|---|------|----------|---------------|----------|---------|------------------------|-------|-----------------|------|-------------|-----------------|-----------|------|----------|
| △ | | | | APPROVED | CHECKED | MATERIAL 材料 | - | CHAMFER 一般面取 | - | QUANTITY 个数 | | | | |
| △ | | | | T. A. | T. A. | TREATMENT 処理 | - | FINISHING 仕上 | - | - | | | | |
| △ | | | | | | TREATMENT CONTACT 処理接点 | - | DECENTRATION 偏芯 | - | | | | | |
| △ | | | | DESIGNED | DRAWN | OVER 250 UP TO 1000 | ±0.3 | ±0.5 | ±1.0 | ±0.2 | REMARK 適用 (機種名) | | | |
| △ | | | | | | OVER 63 UP TO 250 | ±0.2 | ±0.3 | ±0.6 | ±0.15 | | UNIT (mm) | - | SV-3514H |
| △ | | | | T. A. | T. T. | OVER 16 UP TO 63 | ±0.1 | ±0.2 | ±0.4 | ±0.1 | SCALE | 1 / 1 | NAME | |
| △ | | | | | | OVER 0 UP TO 16 | ±0.05 | ±0.1 | ±0.2 | ±0.1 | | | | DATE |
| | DATE | EXCH NO. | REVISION 変更記事 | | | TOLERANCES | Ⓐ | B | C | S | | | | |