

Model	<b>SV-03514V</b>
Focal Length	3.5 mm (3.61)
Maximum Aperture Ratio	1:1.4 (1.40)
F.No	F1.4 ~ Close
Angle of view (1/2")	77.8° × 105.9° (Diagonal: 136.8° )
M.O.D	0.2 m
Flange back	17.526 mm
Operation of Iris & Focus	Manual
Mount	C-mount
Filter Thread	-
TV distortion (1/2")	-14.7 %
Sensor size (max.)	1/2"
Weight (approx.)	53 g
Dimension	$\phi$ 29.5 (MAX) × L= 30.5 mm

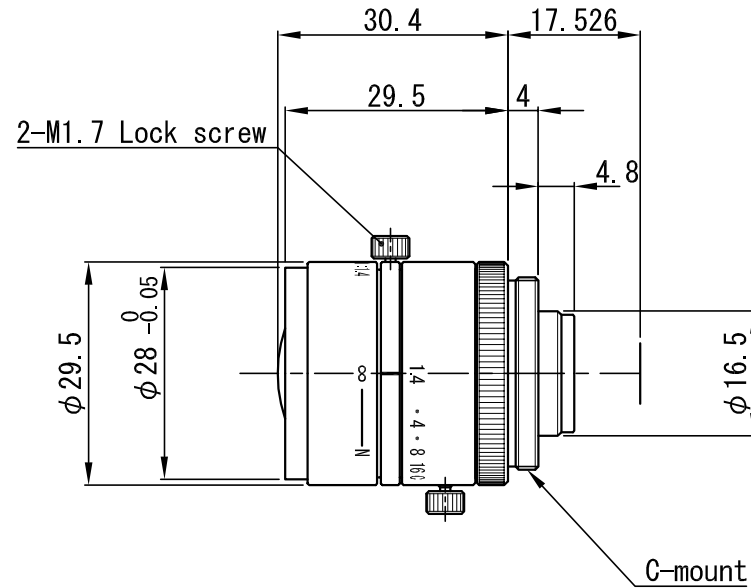

△				APPROVED	CHECKED	MATERIAL 材料	-	CHAMFER 一般面取	-	QUANTITY 个数	
△				T. A.	T. A.	TREATMENT 処理	-	FINISHING 仕上	-	-	
△						TREATMENT CONTACT 処理接点	-	DECENTRATION 偏芯	-		
△				DESIGNED	DRAWN	OVER 250 UP TO 1000	±0.3 ±0.5 ±1.0 ±0.2	ANGLE 角度	METHOD 図法	REMARK 適用 (機種名)	
△				T. A.	T. T.	OVER 63 UP TO 250	±0.2 ±0.3 ±0.6 ±0.15	UNIT (mm)	-		SV-03514V
△						OVER 16 UP TO 63	±0.1 ±0.2 ±0.4 ±0.1				
△						OVER 0 UP TO 16	±0.05 ±0.1 ±0.2 ±0.1	DATE	12.02.14	DRAW NO.	01D SV 0103A 01
	DATE	EXCH NO.	REVISION 変更記事			TOLERANCES	Ⓐ B C S				