

Model	SV-3518V
Focal Length	35 mm (34.75)
Maximum Aperture Ratio	1:1.8 (1.85)
F.No	F1.8 ~ Close
Angle of view (2/3")	10.8° × 14.4° (Diagonal: 18.0° )
M.O.D	300 mm ~ ∞
Flange back	17.526 mm
Operation of Iris & Focus	Manual
Mount	C-mount
Filter Thread	M27 mm P= 0.5
TV distortion (2/3")	-0.13 %
Sensor size (max.)	2/3"
Weight (approx.)	47 g
Dimension	φ 29 (MAX) × L= 33.5 mm

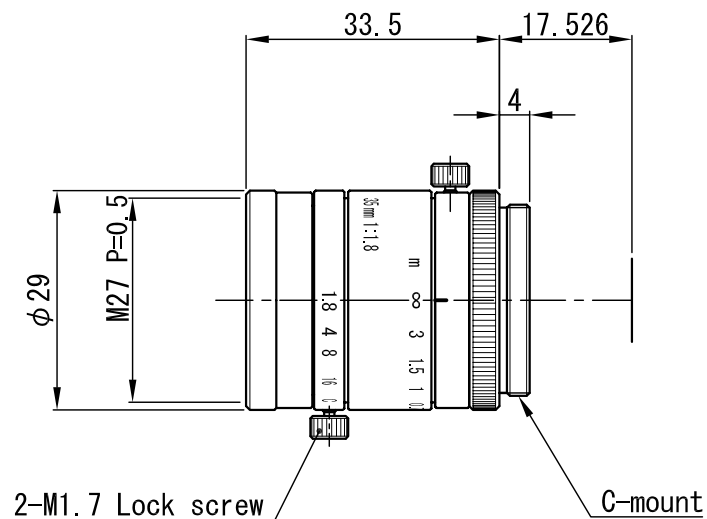

△				APPROVED	CHECKED	MATERIAL 材料	-	CHAMFER 一般面取	-	QUANTITY 個数				
△				T. A.	T. A.	TREATMENT 処理	-	FINISHING 仕上	-	-				
△						TREATMENT CONTACT 処理接点	-	DECENTRATION 偏芯	-					
△				DESIGNED	DRAWN	OVER 250 UP TO 1000	±0.3	±0.5	±1.0	±0.2	UNIT (mm)	ANGLE 角度	METHOD 図法	REMARK 適用 (機種名)
△						OVER 63 UP TO 250	±0.2	±0.3	±0.6	±0.15		-		SV-3518V
△						OVER 16 UP TO 63	±0.1	±0.2	±0.4	±0.1	SCALE	1 / 1	NAME	外觀圖
△						OVER 0 UP TO 16	±0.05	±0.1	±0.2	±0.1				
	DATE	EXCH NO.	REVISION 変更記事	T. A.	T. T.	TOLERANCES	(A)	B	C	S				