

2 Mega Pixel Machine Vision CCTV Lens

Model	VS-5026VM
Focal Length (f)	50 mm (49.99)
Maximum Aperture Ratio	1: 2.6 (2.66)
Aperture	F 2.6 ~ Close
Angle of View (2/3")	8.1° × 9.6° (Diagonal: 12.5°)
M.O.D	400 mm
TV Distortion (2/3")	0.01 %
Operation of Iris & Focus	Manual (Lock screw M2)
Wavelength	Visible
Mount	C-Mount
Flange Back	17.526 mm
Sensor Size (max.)	2/3"
Filter Thread	M 27 P= 0.5
Weight (approx.)	54 g
Dimension	ϕ 29 (max.) × L = 39 mm

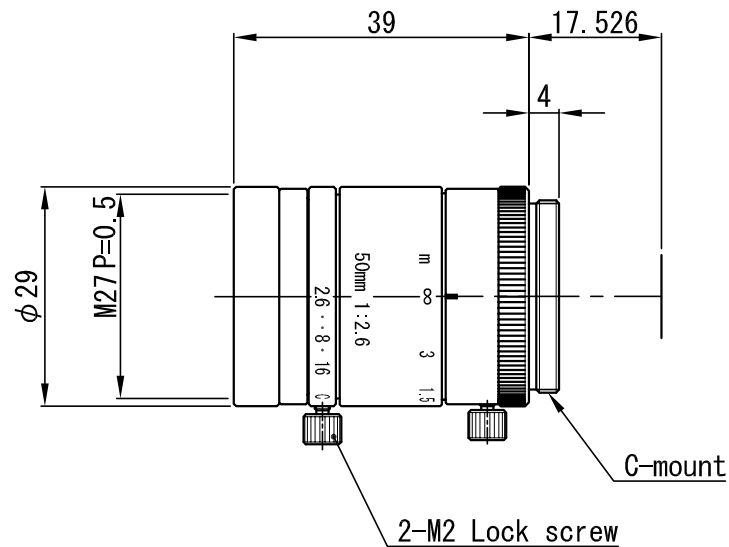

△×				APPROVED	CHECKED	MATERIAL 材料	-	CHAMFER 一般面取	-	QUANTITY 個数				
△×				T. A.	T. A.	TREATMENT 処理	-	FINISHING 仕上	-	-				
△×						TREATMENT CONTACT 処理接点	-	DECENTRATION 偏芯	-					
△×				DESIGNED	DRAWN	OVER 250 UP TO 1000	±0.3 ±0.5 ±1.0 ±0.2	ANGLE 角度	METHOD 図法	REMARK 適用 (機種名)				
△×				T. A.	M. M.	OVER 63 UP TO 250	±0.2 ±0.3 ±0.6 ±0.15	UNIT (mm)	-	VS-5026VM				
△×						OVER 16 UP TO 63	±0.1 ±0.2 ±0.4 ±0.1				SCALE	1 / 1	NAME	外觀図
△×						OVER 0 UP TO 16	±0.05 ±0.1 ±0.2 ±0.1				DATE	16.03.03	DRAW NO.	01D S V 0 1 4 9 A 1
NO. × 箇所	REVISION 訂正事項	DATE	NAME			TOLERANCES	A B C S							