

Line Scan Macro Lens

Model	VS-L5028/F			
Focal Length (f)	50 mm (51.38)			
Optical Mag. Range	× 0.05 ~ × 0.3			
Optical Mag.	× 0.05	× 0.1	× 0.2	× 0.3
WD	1025.0 mm	513.7 mm	261.9 mm	181.4 mm
O/I (Object & Imager Distance)	1129.5 mm	618.2 mm	366.4 mm	285.9 mm
Aperture	F 2.8 ~ 16			
Working F/# *Value at Iris Open	3.1	3.2	3.5	3.8
DOF at PCoC $\phi$ 0.04mm	99.2 mm	25.6 mm	7.0 mm	3.4 mm
Optical Distortion (Y=22.5)	-0.02 %			
Operation	Manual (Lock Screw M2)			
Wavelength	Visible			
Mount	F-Mount			
Flange Back	46.5 mm			
Image Circle	$\phi$ 45 mm			
Filter Thread	M 62 P= 0.75			
Weight (approx.)	290 g			
Dimension	$\phi$ 66 (max.) × L = 58 mm			

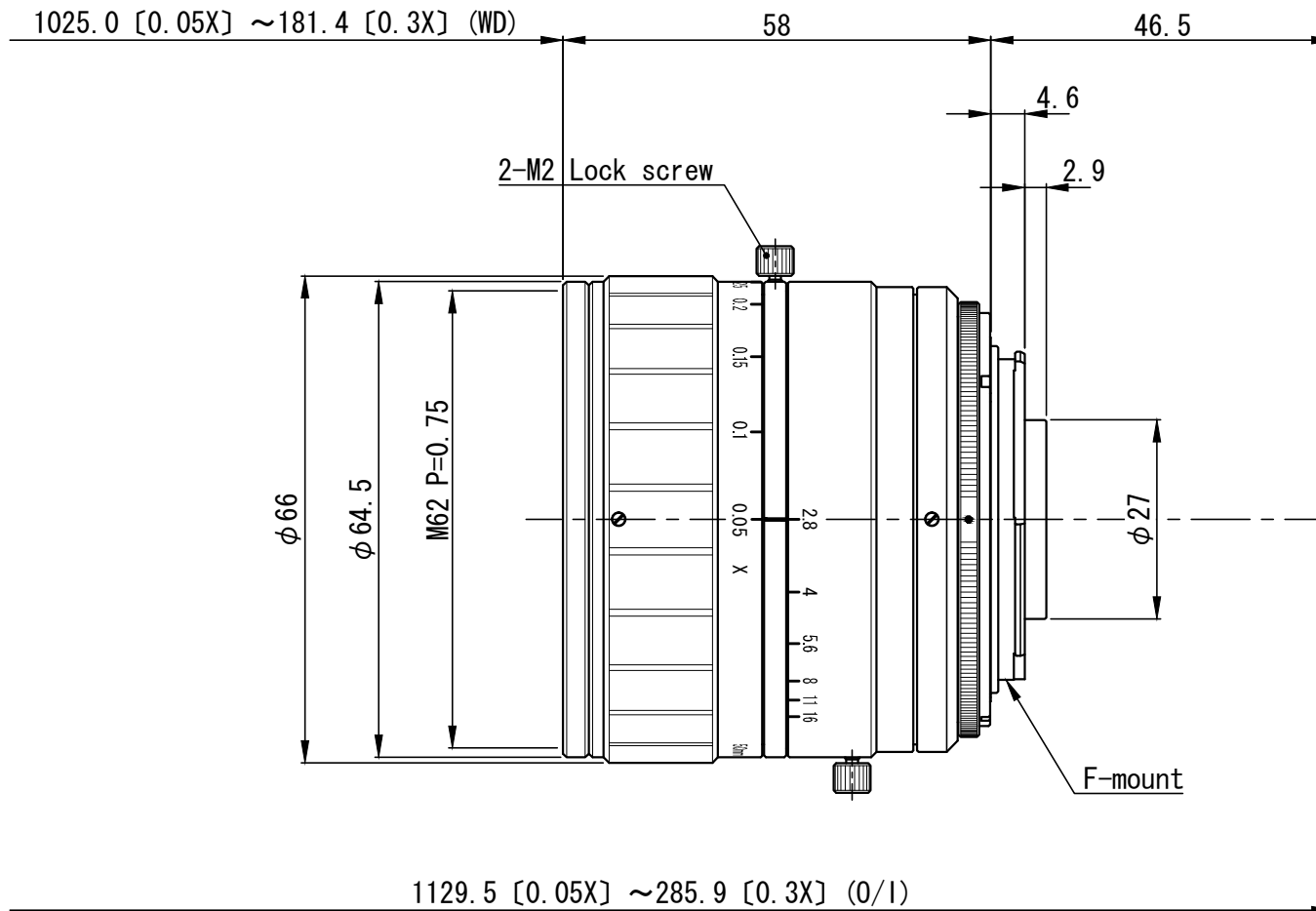

△				APPROVED	CHECKED	MATERIAL 材料	-	CHAMFER 一般面取	-	QUANTITY 個数
△				T. A.	T. A.	TREATMENT 処理	-	FINISHING 仕上	-	-
△						TREATMENT CONTACT 処理接点	-	DECENTRATION 偏芯	-	
△				DESIGNED	DRAWN	OVER 250 UP TO 1000 ±0.3 ±0.5 ±1.0 ±0.2	UNIT (mm)	ANGLE 角度	METHOD 図法	REMARK 適用 (機種名)
△				T. A.	T. T.	OVER 63 UP TO 250 ±0.2 ±0.3 ±0.6 ±0.15		-		VS-L5028/F
△						OVER 16 UP TO 63 ±0.1 ±0.2 ±0.4 ±0.1	SCALE	1 / 1		
△				T. A.	T. T.	OVER 0 UP TO 16 ±0.05 ±0.1 ±0.2 ±0.1	DATE	11.05.18	DRAW NO.	ODM C 0161A1
	DATE	EXCH NO.	REVISION 変更記事			TOLERANCES	(A) B C S			