

Line Scan Macro Lens

Model	VS-L5045FL/M72S		
Focal Length (f)	52.5 mm		
Optical Mag. Range	(∞) \times 0.03 \sim \times 0.15		
Optical Mag.	\times 0.03	\times 0.10	\times 0.15
WD	1763.4 mm	545.2 mm	373.7 mm
O/I (Object & Imager Distance)	1884.9 mm	666.7 mm	495.2 mm
Aperture	F 4.5 \sim 22		
Working F/# *Value at Iris Open	4.7	5.0	5.3
Optical Distortion (Y=37.5)	0.00 %	0.15 %	0.22 %
Relative Illuminance (Y=37.5)	48 %		
Operation	Manual (Lock Screw M2)		
Wavelength	Visible		
Mount	M 72 P= 0.75		
Flange Back	31.8 mm		
Image Circle	ϕ 75 mm		
Filter Thread	M 86 P= 1.0		
Weight (approx.)	910 g		
Dimension	ϕ 90 (max.) \times L = 89.7 mm		

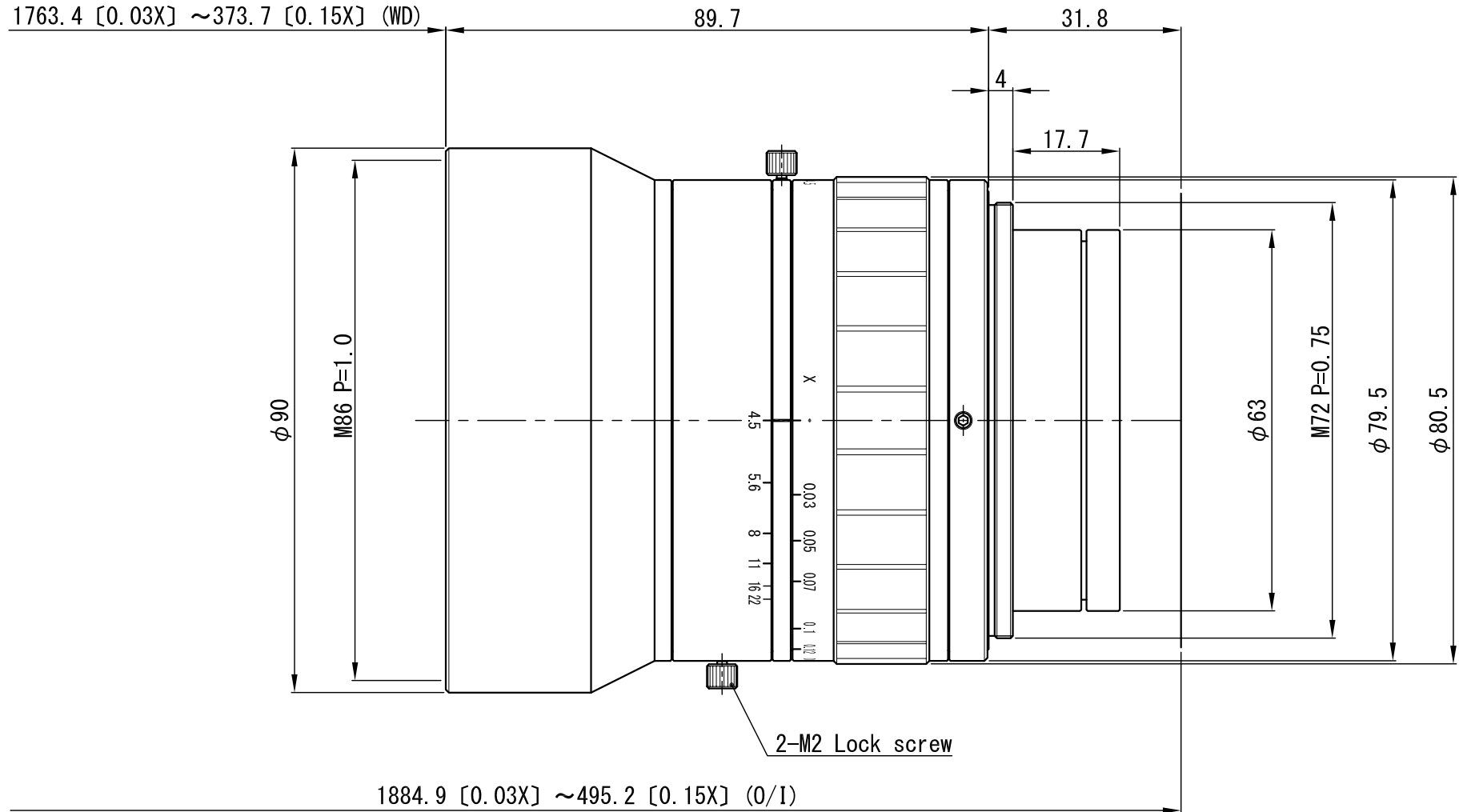

△×				APPROVED	CHECKED	MATERIAL 材料	-	CHAMFER 一般面取	-	QUANTITY 個数		
△×				T. A.	T. A.	TREATMENT 処理	-	FINISHING 仕上	-	-		
△×						TREATMENT CONTACT 処理接点	-	DECENTRATION 偏芯	-			
△×				DESIGNED	DRAWN	OVER 250 UP TO 1000	±0.3 ±0.5 ±1.0 ±0.2	ANGLE 角度	METHOD 図法	REMARK 適用 (機種名)		
△×				T. A.	H. M.	OVER 63 UP TO 250	±0.2 ±0.3 ±0.6 ±0.15	UNIT (mm)	-	VS-L5045FL / M72S		
△×						OVER 16 UP TO 63	±0.1 ±0.2 ±0.4 ±0.1	SCALE	1 / 1		NAME	外觀圖
△×						OVER 0 UP TO 16	±0.05 ±0.1 ±0.2 ±0.1	DATE	18.05.09		DRAW NO.	0D MC 0397A1
NO. × 箇所	REVISION 訂正事項	DATE	NAME			TOLERANCES	A B C S					