

Ultra-High Resolution Telecentric Lens

Model		VS-TCT08-65/S			
Optical Mag.		× 0.8 ± 5 %			
FOV (V x H)	2/3"	8.9	×	10.5	mm
	1/2"	6.0	×	8.0	mm
	1/3"	4.5	×	6.0	mm
WD		65.1 mm ± 2			
O/I (Object & Imager Distance)		178.6 mm			
Working F/# *Value at Iris Open		4.5			
NA		0.089			
DOF at PCoC ϕ 0.04mm		0.6 mm			
TV Distortion (2/3")		0.00 %			
Relative Illuminance (Y=5.5)		98 %			
Wavelength		Visible			
Mount		C-Mount			
Flange Back		17.526 mm			
Sensor Size (max.)		2/3"			
Co-Axial Prism		-			
Filter Thread		M 34 P= 0.5			
Weight (approx.)		200 g			
Dimension		ϕ 36.5 (max.)	×	L =	96 mm

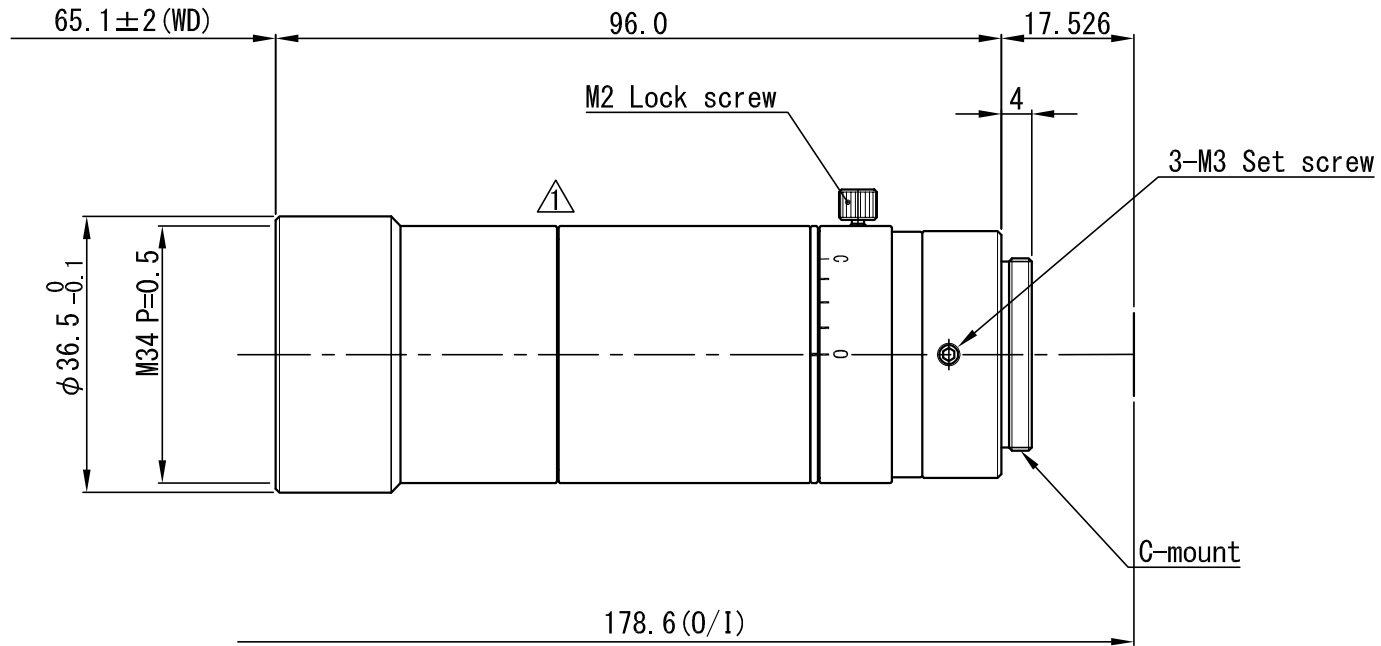

△ ×				APPROVED	CHECKED	MATERIAL 材料	-	CHAMFER 一般面取	-	QUANTITY 個数	
△ ×				T. A.	T. A.	TREATMENT 処理	-	FINISHING 仕上	-	-	
△ ×						TREATMENT CONTACT 処理接点	-	DECENTRATION 偏芯	-		
△ ×				DESIGNED	DRAWN	OVER 250 UP TO 1000 ±0.3 ±0.5 ±1.0 ±0.2	UNIT (mm)	ANGLE 角度	METHOD 図法	REMARK 適用 (機種名)	
△ ×						OVER 63 UP TO 250 ±0.2 ±0.3 ±0.6 ±0.15		-		V S - T C T 0 8 - 6 5 / S	
△ × 1	形状変更	16.08.23	T. T.	T. A.	T. T.	OVER 16 UP TO 63 ±0.1 ±0.2 ±0.4 ±0.1		SCALE	1 / 1	NAME	外觀図
NO. × 箇所	REVISION 訂正事項	DATE	NAME			TOLERANCES		A B C S	DATE	15.10.06	DRAW NO.