

Variable Magnification Telecentric Lens

| Model | | VS-TEC0304 | | | |
|---------------------------------|------|-------------------------------|----------------|----------------|--|
| Optical Mag. Range | | × 0.3 ~ × 0.4 | | | |
| Optical Mag. | | × 0.3 | × 0.35 | × 0.4 | |
| FOV (V × H) | 2/3" | 23.7 × 28.0 mm | 20.3 × 24.0 mm | 17.8 × 21.0 mm | |
| | 1/2" | 16.0 × 21.3 mm | 13.7 × 18.3 mm | 12.0 × 16.0 mm | |
| | 1/3" | 12.0 × 16.0 mm | 10.3 × 13.7 mm | 9.0 × 12.0 mm | |
| WD | | 212.1 mm | 175.1 mm | 147.8 mm | |
| O/I (Object & Imager Distance) | | 353.6 mm | 316.6 mm | 289.3 mm | |
| Working F/# *Value at Iris Open | | 4.3 | 4.7 | 5.0 | |
| NA | | 0.035 | 0.038 | 0.040 | |
| DOF at PCoC ϕ 0.04mm | | 3.8 mm | 3.0 mm | 2.5 mm | |
| TV Distortion (2/3") | | 0.02 % | -0.01 % | -0.03 % | |
| Relative Illuminance (Y=5.5) | | 98 % | 98 % | 98 % | |
| Wavelength | | Visible | | | |
| Mount | | C-Mount | | | |
| Flange Back | | 17.526 mm | | | |
| Sensor Size (max.) | | 2/3" | | | |
| Filter Thread | | M 49 P= 0.75 | | | |
| Weight (approx.) | | 360 g | | | |
| Dimension | | ϕ 54 (max.) × L = 124 mm | | | |

0.3X 212.1±6.5
 0.35X 175.1±5 (WD)
 0.4X 147.8±4.5

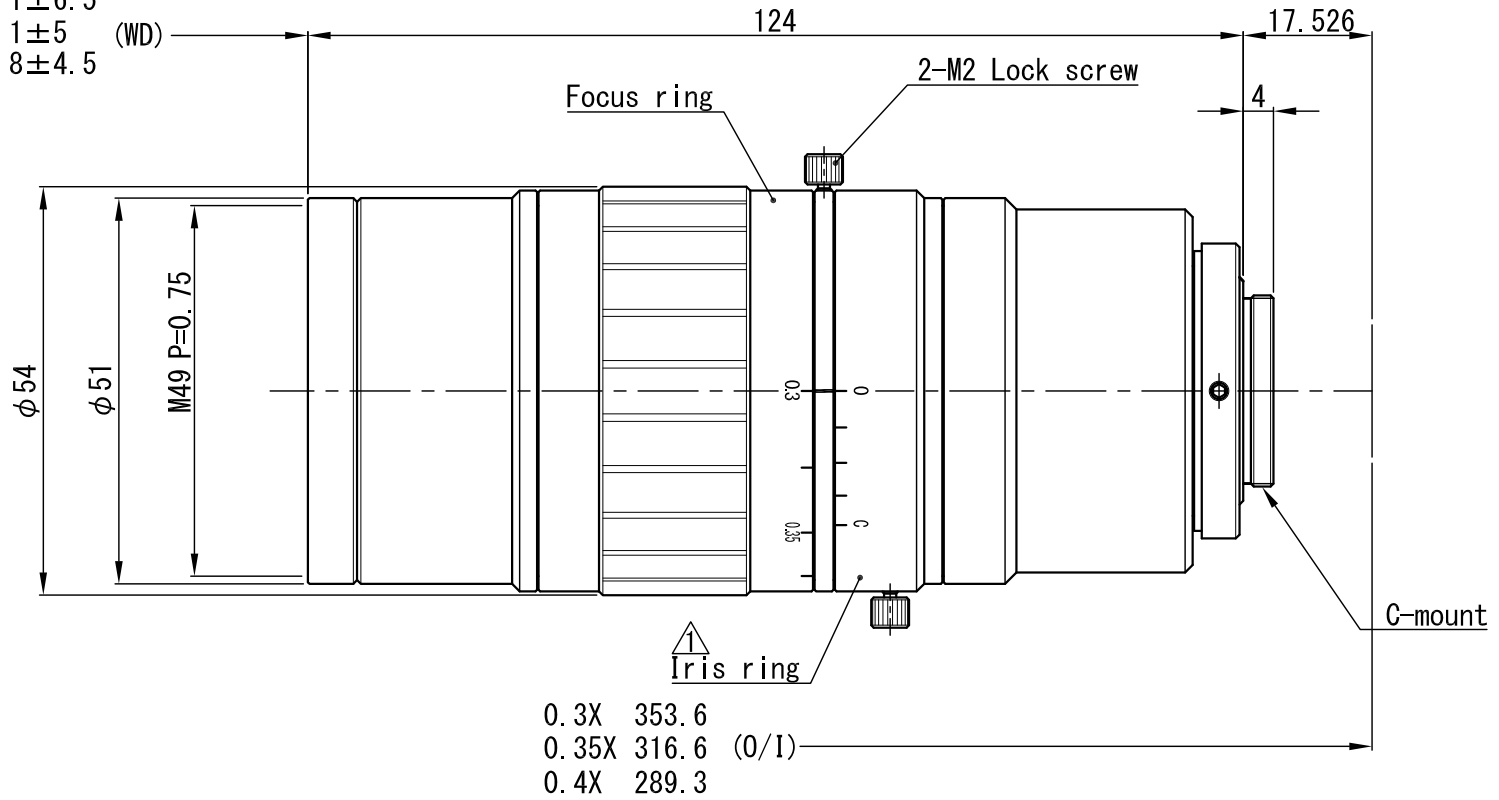

| | | | | | | | | | | | | | | |
|--------|---------------|----------|------|------------|---------|------------------------|----------------------|-----------------|-----------|-----------------|-------|------------|----------|---------------|
| △× | | | | APPROVED | CHECKED | MATERIAL 材料 | - | CHAMFER 一般面取 | - | QUANTITY 個数 | | | | |
| △× | | | | T. A. | T. A. | TREATMENT 処理 | - | FINISHING 仕上 | - | - | | | | |
| △× | | | | | | TREATMENT CONTACT 処理接点 | - | DECENTRATION 偏芯 | - | | | | | |
| △× | | | | DESIGNED | DRAWN | OVER 250 UP TO 1000 | ±0.3 ±0.5 ±1.0 ±0.2 | ANGLE 角度 | METHOD 図法 | REMARK 適用 (機種名) | | | | |
| △× | | | | T. A. | T. T. | OVER 63 UP TO 250 | ±0.2 ±0.3 ±0.6 ±0.15 | UNIT (mm) | - | VS-TEC0304 | | | | |
| △× 1 | Iris ring表記追加 | 19.03.03 | T.F. | | | OVER 16 UP TO 63 | ±0.1 ±0.2 ±0.4 ±0.1 | | | | SCALE | 1 / 1 | NAME | DRAWING / 外觀図 |
| NO.×箇所 | REVISION 訂正事項 | DATE | NAME | | | OVER 0 UP TO 16 | ±0.05 ±0.1 ±0.2 ±0.1 | | | | DATE | ' 11.04.12 | DRAW NO. | 01010E0369A2 |
| | | | | TOLERANCES | | A | B | C | S | | | | | |