

Variable Magnification Telecentric Lens

Model		VS-TEV0305			
Optical Mag. Range		× 0.3 ~ × 0.5			
Optical Mag.		× 0.3	× 0.4	× 0.5	
FOV (V × H)	1.1"	34.7 × 47.0 mm	26.0 × 35.3 mm	20.8 × 28.2 mm	
	1"	37.5 × 37.5 mm	28.2 × 28.2 mm	22.5 × 22.5 mm	
	2/3"	23.7 × 28.0 mm	17.8 × 21.0 mm	14.2 × 16.8 mm	
WD		221.5 mm	162.0 mm	125.8 mm	
O/I (Object & Imager Distance)		347.0 mm	296.7 mm	269.6 mm	
Working F/# *Value at Iris Open		4.3	5.2	6.2	
NA		0.035	0.038	0.040	
DOF at PCoC ϕ 0.04mm		3.8 mm	2.6 mm	2.0 mm	
TV Distortion (1.1")		0.03 %	-0.04 %	-0.04 %	
Relative Illuminance (Y=8.8)		72 %	97 %	97 %	
Wavelength		Visible			
Mount		C-Mount			
Flange Back		17.526 mm			
Sensor Size (max.)		1.1"			
Filter Thread		M 52 P= 0.75			
Weight (approx.)		390 g			
Dimension		ϕ 55 (max.) × L = 108.0 (X0.3) ~ 126.3 (X0.5) mm			

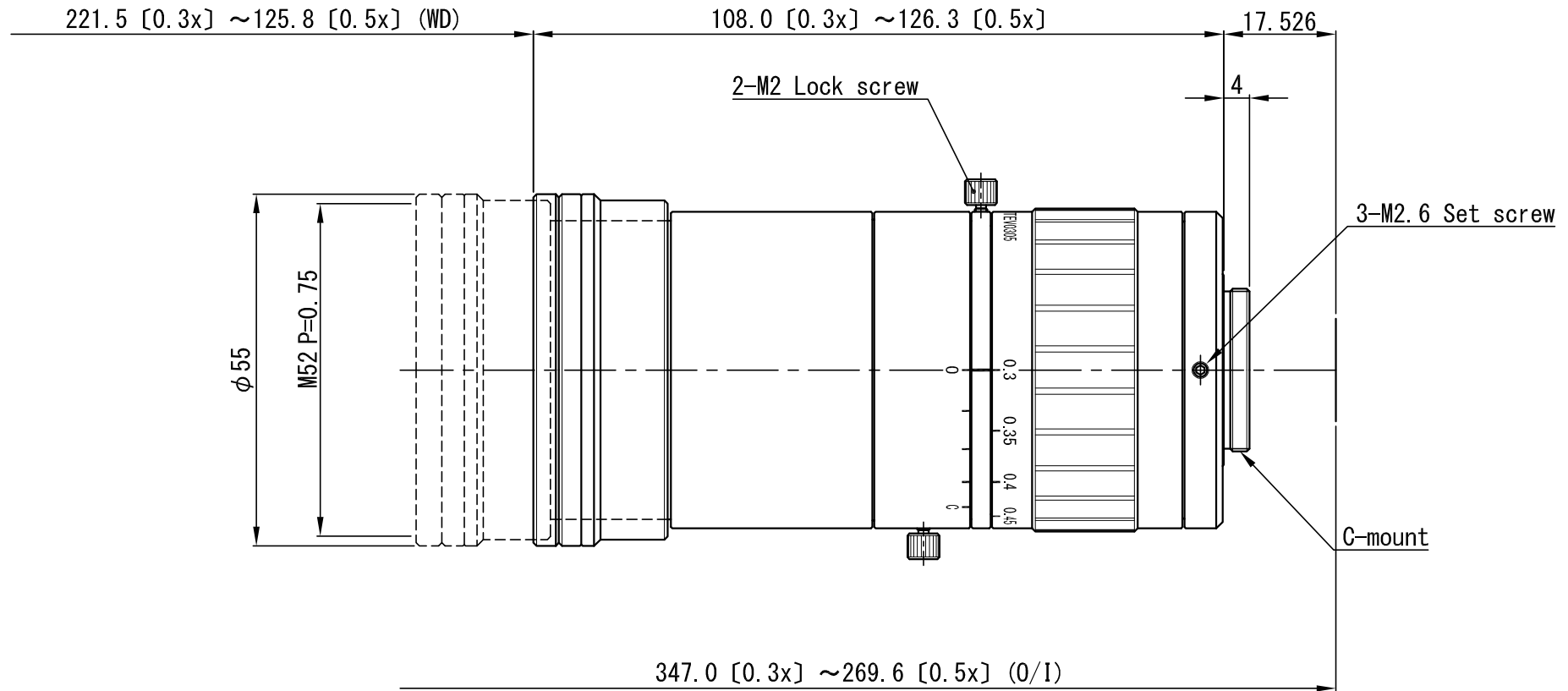

△×				APPROVED	CHECKED	MATERIAL 材料	-	CHAMFER 一般面取	-	QUANTITY 個数				
△×				T. A.	T. A.	TREATMENT 処理	-	FINISHING 仕上	-	-				
△×						TREATMENT CONTACT 処理接点	-	DECENTRATION 偏芯	-					
△×				DESIGNED	DRAWN	OVER 250 UP TO 1000	±0.3 ±0.5 ±1.0 ±0.2	ANGLE 角度	METHOD 図法	REMARK 適用 (機種名)				
△×				T. A.	T. T.	OVER 63 UP TO 250	±0.2 ±0.3 ±0.6 ±0.15	UNIT (mm)	-	VS-TEV0305				
△×						OVER 16 UP TO 63	±0.1 ±0.2 ±0.4 ±0.1				SCALE	1 / 1	NAME	外觀図
△×						OVER 0 UP TO 16	±0.05 ±0.1 ±0.2 ±0.1				DATE	16.07.26	DRAW NO.	01DTC0559A1
NO. × 箇所	REVISION 訂正事項	DATE	NAME			TOLERANCES	A B C S							