

## Zoom Lens

Model		<b>VSZ-0530</b>					
Optical Mag. Range		× 0.47    ~    × 3.0					
Optical Mag.		× 0.47		× 1.2		× 3.0	
FOV (V × H)	1/1.8"	11.5 × 15.1 mm		4.5 × 5.9 mm		1.8 × 2.4 mm	
	1/2"	10.2 × 13.6 mm		4.0 × 5.3 mm		1.6 × 2.1 mm	
	1/3"	7.7 × 10.2 mm		3.0 × 4.0 mm		1.2 × 1.6 mm	
WD		100.0 mm ± 3					
O/I (Object & Imager Distance)		267.8 mm					
Working F/# *Value at Iris Open		6.9		9.3		19.8	
NA		0.034		0.065		0.076	
DOF at PCoC $\phi$ 0.04mm		2.5 mm		0.5 mm		0.2 mm	
TV Distortion (1/1.8")		-0.09 %		0.12 %		0.11 %	
Relative Illuminance (Y=4.4)		51 %		77 %		99 %	
Wavelength		Visible					
Mount		C-Mount					
Flange Back		17.526 mm					
Sensor Size (max.)		1/1.8"					
Co-Axial Prism		-					
Weight (approx.)		230 g					
Dimension		$\phi$ 38 (max.) × L = 150.3 mm					

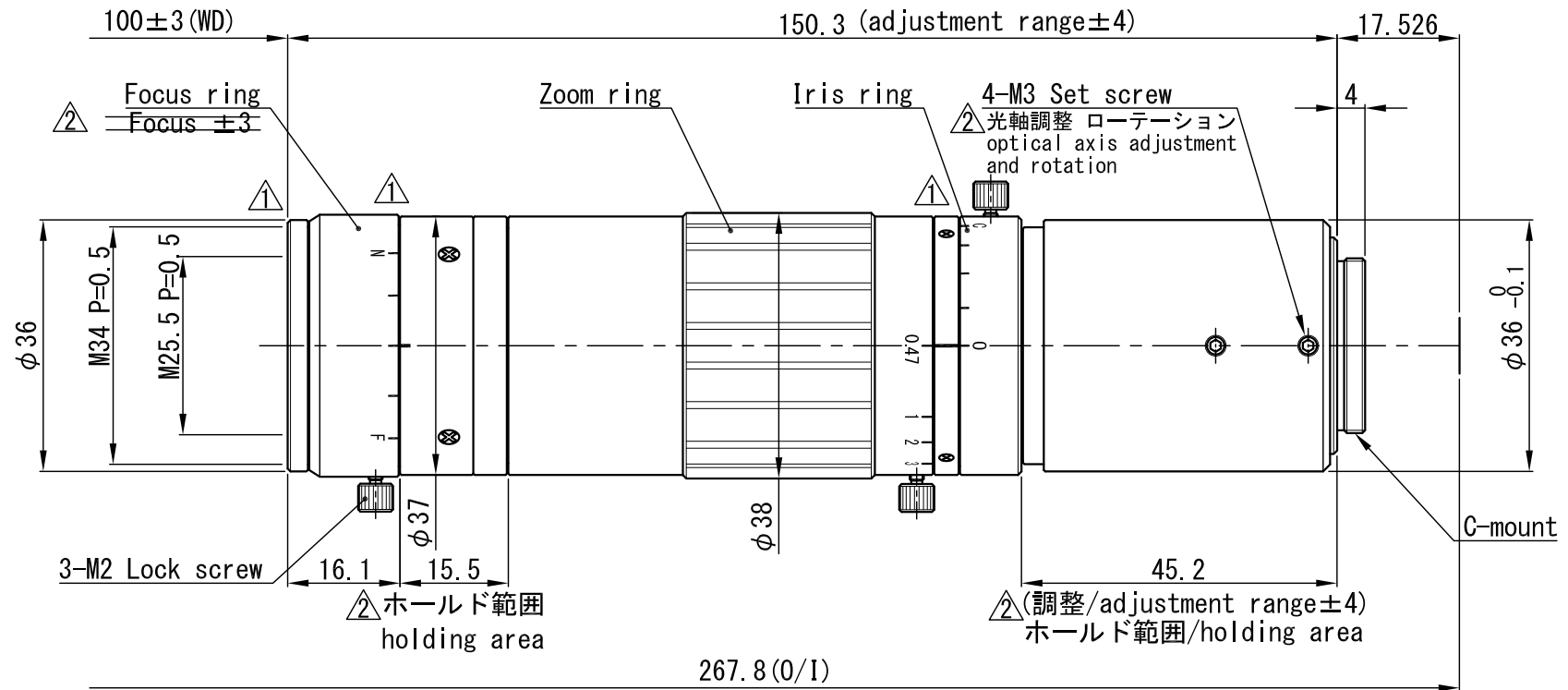

△×				APPROVED	CHECKED	MATERIAL 材料	-	CHAMFER 一般面取	-	QUANTITY 個数	
△×				T. A.	T. A.	TREATMENT 処理	-	FINISHING 仕上	-	-	
△×						TREATMENT CONTACT 処理接点	-	DECENTRATION 偏芯	-	-	
△×						OVER 250 UP TO 1000 ±0.3 ±0.5 ±1.0 ±0.2	UNIT (mm)	ANGLE 角度	METHOD 図法	REMARK 適用 (機種名)	
△×	Focus ±3 削除 / 表記変更	19.03.03	T. F.	DESIGNED	DRAWN	OVER 63 UP TO 250 ±0.2 ±0.3 ±0.6 ±0.15		-		V S Z - 0 5 3 0	
△×	外観変更 (ブルーライン削除×1) (フォーカス目盛変更×1、絞り目盛変更×1)	17.06.14	T. T.	T. A.	T. T.	OVER 16 UP TO 63 ±0.1 ±0.2 ±0.4 ±0.1		SCALE	1 / 1	NAME	D R A W I N G / 外 観 図
NO.×箇所	REVISION 訂正事項	DATE	NAME			OVER 0 UP TO 16 ±0.05 ±0.1 ±0.2 ±0.1		DATE	11.04.22	DRAW NO.	0   D   M   Z   0   0   6   7   A   3
TOLERANCES		A	B	C	S						